

Stacking Counterbalance Valve, size 2 Direct Acting Series SNKA ...



- 250 bar, 25 l/min
- Direct acting, spool type
- Controlled movement of negative loads
- Functional parts in side-mounted body
- 5 pressure ranges
- User-modifiable to hand knob or lockable hand knob adjustment
- with ISO 4401-02-01 interface

1. Description

Series SNKA-TB-4 units are stack mounting counterbalance valves which provide controlled movement of negative loads. The valve setting should always be higher than the level of the load-induced pressure in line B. This ensures that a certain minimum pressure must exist in line A before the

load can be lowered. When lifting the load, the pressure in P (B) is always higher than the valve setting (see Application Example). **WARNING:** If used with WEDA-...-4 directional valve, the counterbalance valve setting must not exceed 160 bar. (WEDA-...-4 maximum tank line pressure = 160 bar)

The $\varnothing 3$ mm location pin on the actuator face of the valve prevents incorrect mounting. Valves are shipped as standard with screw adjustment. Alternatively, they can be supplied with adjustment by hand knob, or lockable hand knob.

2. Symbols

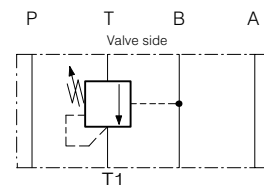

SNKA-TB-4 ...

3. Main characteristics

Designation		counterbalance slice valve
Design		direct acting spoolvalve
Mounting method		stack mounting
Size		ISO 4401-02-01 interface
Weight	kg	0,83
Mounting attitude		unrestricted
Flow direction		see symbol
Operating pressure range	bar	... 250 in P, A and B; ... 160 in T
Adjustment ranges	bar	code 25 = ... 250 code 16 = ... 160 code 10 = ... 100 code 04 = ... 040 code 02 = ... 020
Flow rate, Q max.	l/min	25
Fluids		HL and HLP hydraulic oils to DIN 51 524; for other fluids, please consult BUCHER

Fluid temperature range	°C	-25 ... +80
Ambient temperature	°C	-25 ... +80
Viscosity range	mm ² /s (cSt)	10 ... 650, recommended 15 ... 250
Minimum fluid cleanliness level		18/14 to ISO 4406 / CETOP RP70H; 8 ... 9 to NAS 1638

4. Application example

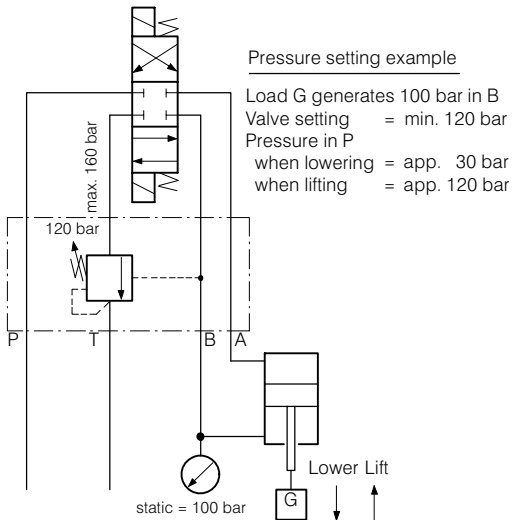

Warning:
 Allowable pressure in T port of directional valve WEDA-...-4 is 160 bar max.

5. Performance graphs

Measured with oil viscosity 33 mm²/s (cSt)

The pressure drop from T ⇒ T1 has no significant effect on the curves

*) not intended for use with WEDA-...-4

Rate of pressure change when turning the adjusting screw:

SNKA-TB-4-25:	1 turn ≅ app. 48 bar
SNKA-TB-4-16:	1 turn ≅ app. 30 bar
SNKA-TB-4-10:	1 turn ≅ app. 20 bar
SNKA-TB-4-04:	1 turn ≅ app. 8 bar
SNKA-TB-4-02:	1 turn ≅ app. 3 bar

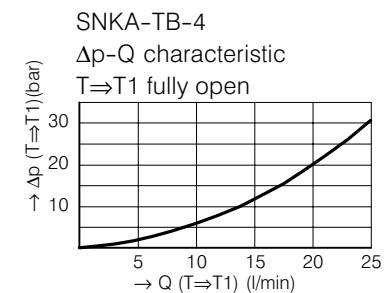
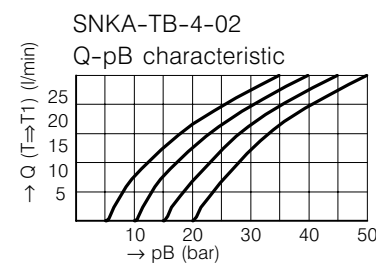
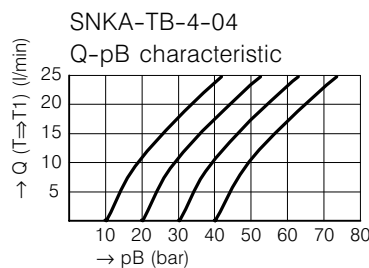
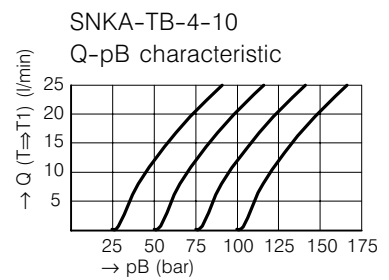
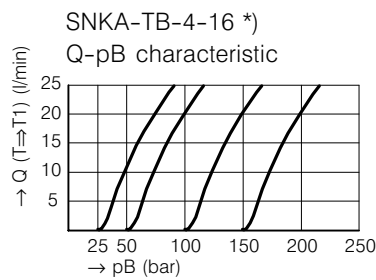
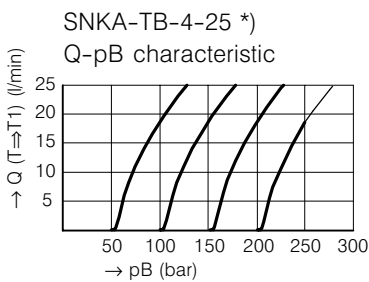

6. Dimensions

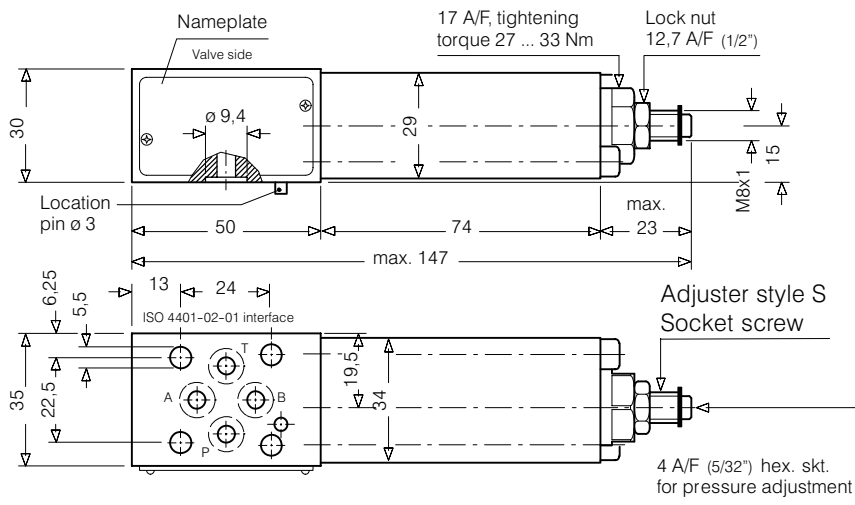

Adjuster styles / OPTIONAL

Conversion kit for styles S, H and Z5 - see related data sheets

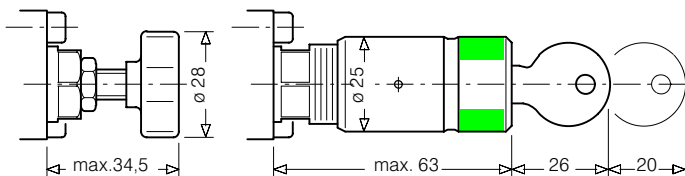

Adjuster style H
Hand knob

Adjuster style Z5, lockable hand type 2H.
Complies with Volkswagen factory specification BV 1.09

7. Schematic section

showing the relevant ports

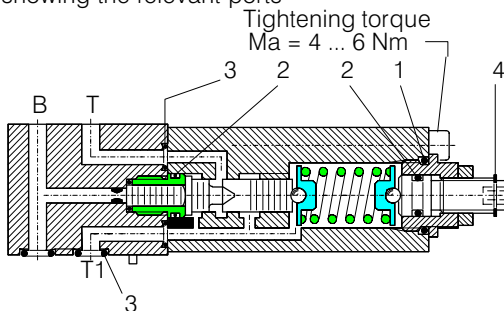

Seal kit no. DS-213, comprising:

Itm.	Qty.	Description	Size
1	1	O-ring no. 016	Ø 15,60 X 1,78 N90
2	2	O-ring no. 009	Ø 5,28 x 1,78 N90
3	6	O-ring no. 010	Ø 6,07 x 1,78 N90
4	1	Snap ring	Type SS Ø 7

SNKA-TB-4-02/-04/-10/-16/-25

8. Installation and servicing

All installation and servicing must be carried out with care, and by qualified personnel only. At installation, be sure to mount the valve the correct way up.

Do not confuse the flat surface (directional valve side) and the surface with O-ring counter-bores (actuator side).

When changing seals, the new seals should be thoroughly oiled or greased before fitting them to the valve.

9. Ordering code

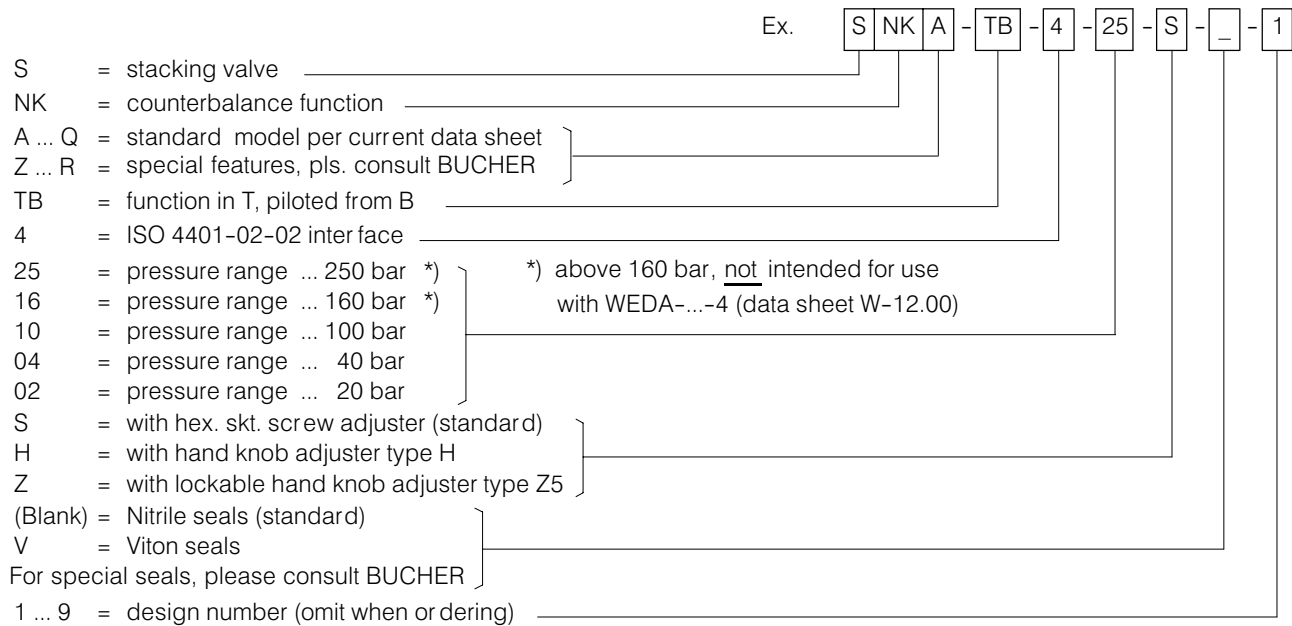

10. Related data sheets

Old no.	New no.	
i - 17.00	400-P-015101-E	Procedure for changing the Adjuster Style
i - 30	400-P-030101-E	ISO 4401-02-01 interface

BUCHER HYDRAULICS

Germany

Phone +49 7742 85 20
 Fax +49 7742 71 16
 info.de@bucherhydraulics.com

France

Phone +33 389 64 22 44
 Fax +33 389 65 26 78
 info.fr@bucherhydraulics.com

Netherlands

Phone +31 79 34 26 24 4
 Fax +31 79 34 26 28 8
 info.nl@bucherhydraulics.com

UK

Phone +44 24 76 35 35 61
 Fax +44 24 76 35 35 72
 info.uk@bucherhydraulics.com

USA

Phone +1 262 605 82 80
 Fax +1 262 605 82 78
 info.wi@bucherhydraulics.com

www.bucherhydraulics.com

Switzerland

Phone +41 33 67 26 11 1
 Fax +41 33 67 26 10 3
 info.ch@bucherhydraulics.com

Italy

Phone +39 0522 92 84 11
 Fax +39 0522 51 32 11
 info.it@bucherhydraulics.com

Austria

Phone +43 6216 44 97
 Fax +43 6216 44 97 4

China

Phone +86 10 64 44 32 88
 Fax +86 10 64 44 32 35
 info.bj@bucherhydraulics.com

Product Center (Elevator)

Phone +41 41 757 03 33
 Fax +41 41 757 16 49
 info.nh@bucherhydraulics.com

We reserve the right of modification without notice.