

AP212 Gear Pumps

Standard and Low Noise series

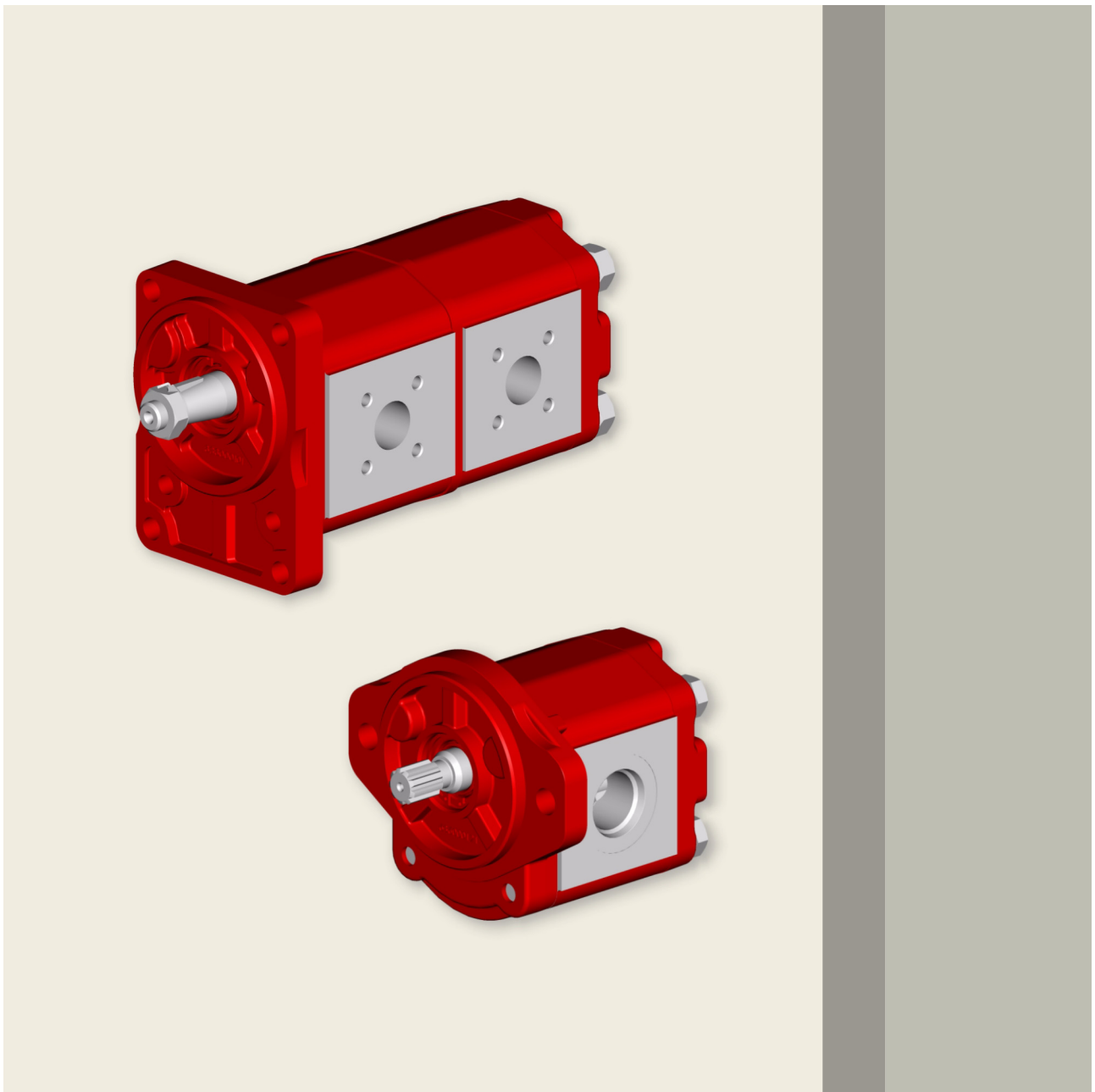

motion and progress

Contents

Page

1	General information	3
1.1	External gear pumps components	4
1.2	Example of typical sound pressure level recorded in a semi-anechoic testing room	5
1.3	Technical data	6
1.4	Pressure	6
1.5	Suction	7
1.6	General precaution	7
1.7	Identifying the rotation direction	8
1.8	Motor-pump coupling	8
1.9	Non-standard symbols used in the text	9
1.10	Calculating the specification of a gear pump	9
2	Overview standard types	10
2.1	Standard configuration	10
3	AP212 Single pump customised versions	28
3.1	Single pump customised versions order example	29
3.2	Single pump dimensions	30
3.3	Shaft end code	31
3.4	Front cover	32
3.5	Body	35
3.6	Back covers	38
4	Multiple gear pumps	42
4.1	Drive torque	42
4.2	Tandem pumps dimensions (standard version without shaft seal between the pumps)	43
4.3	Tandem pumps dimensions (special version with shaft seal between the pumps)	44
4.4	Triple pumps dimensions (standard version without shaft seal between the pumps)	45
4.5	Triple pumps dimensions (special version with shaft seal between the pumps)	46
4.6	How to order tandem pumps (with or without shaft seal between the pumps)	47
4.7	How to order triple pumps (with or without shaft seal between the pumps)	47
4.8	Tandem pumps dimensions AP212 + AP100 (with shaft seal between the pumps)	48
4.9	How to order tandem pumps AP212 + AP100 (with shaft seal between the pumps)	49
5	Rotation changing instructions	50
6	Pumps seal kit NBR standard type	51
7	Product identification plate	52
8	Application form	53

1 General information

The product range of Bucher Hydraulics SpA includes single pumps 05-100-212-300 (corresponding with the common group denominations: 05-1-2-3) and several combinations of double pumps, triple pumps, and so on, that can be assembled together according to versions of displacement, flanging, and auxiliary valves .

External gear pumps are widely used in modern hydraulic systems due to their high performance, long service life and low purchase and maintenance costs.

Here following we introduce you the new AP212 family range.

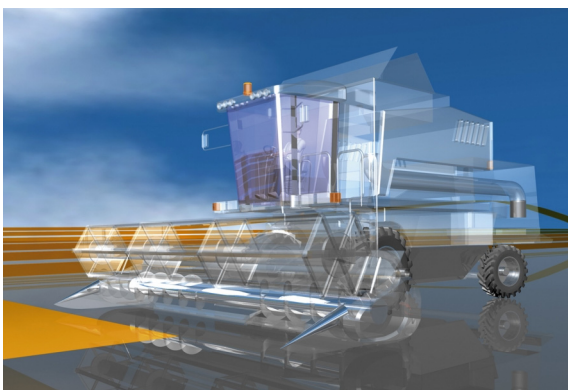

Product development of the new AP212 family has made it possible to achieve high operating pressures, excellent volumetric and mechanical efficiency and on specially developed units (LN – Low Noise) even lower noise levels.

This has been possible by means of:

- new design of gear teeth and balancing areas
- use of high-performance materials
- carefully controlled heat treatments

- increasingly tight coupling tolerances and a high standard of surface finish

- continuous development in our semi-anechoic room

Bucher Hydraulics has so achieved these results by constantly improving its design, control and manufacturing techniques inline with the latest technological developments, while simultaneously enhancing our Quality Control System which ensures that every single product offers the same high standards.

1.1 External gear pumps components

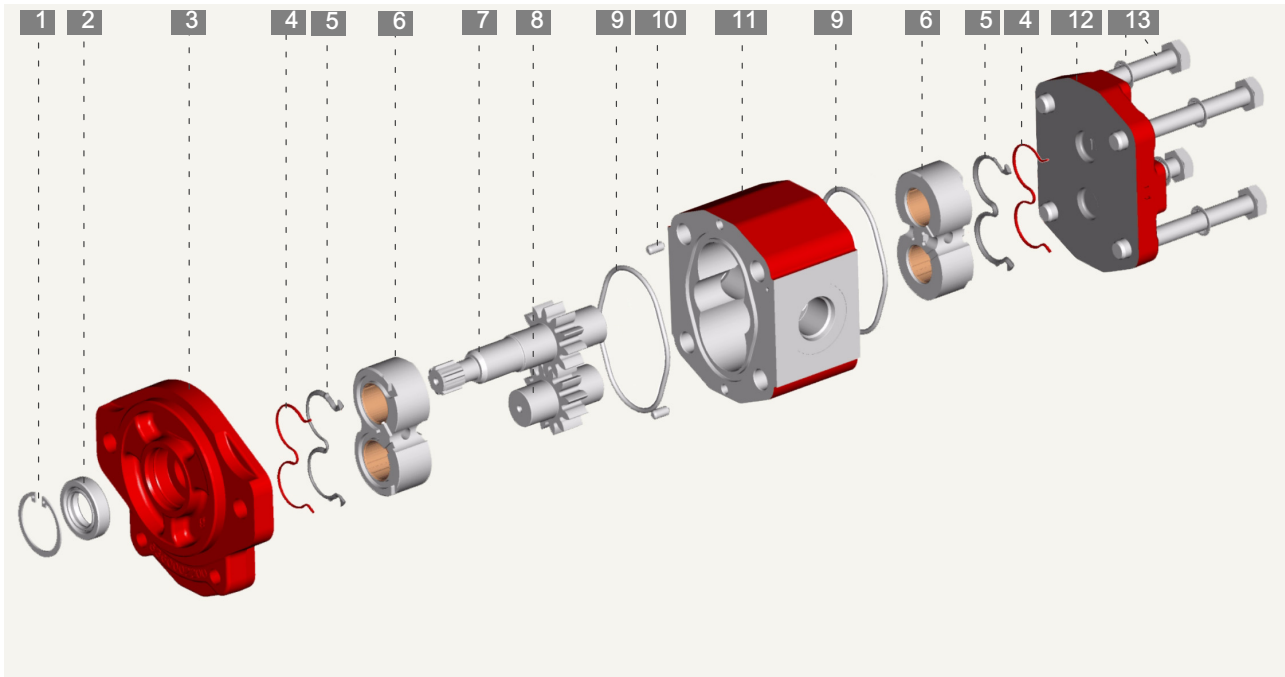

- 24. Retaining ring
- 25. Shaft seal
- 26. Front cover
- 27. Balancing seal
- 28. Back up seal
- 29. Balancing block
- 30. Drive gear

- 31. Driven gear
- 32. Oil seal
- 33. Centering pin
- 34. Pump body
- 35. Back cover
- 36. Fixing screw and washer

1.1.1 Improvements (New AP212 vs AP200)

Front covers :

In addition to aluminium versions, complete new range of cast iron front covers

Balancing blocks :

New generation optimised and standardised balancing blocks

Gears :

New gears profile (12 teeth) with increased transmissible torque

Bodies:

New design pump bodies

Back covers:

Wide range of aluminium and cast iron back covers with/without integrated cartridge valves

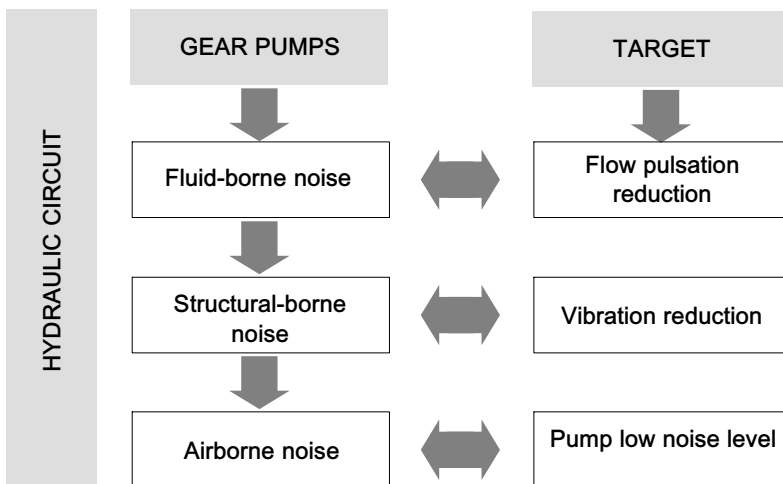

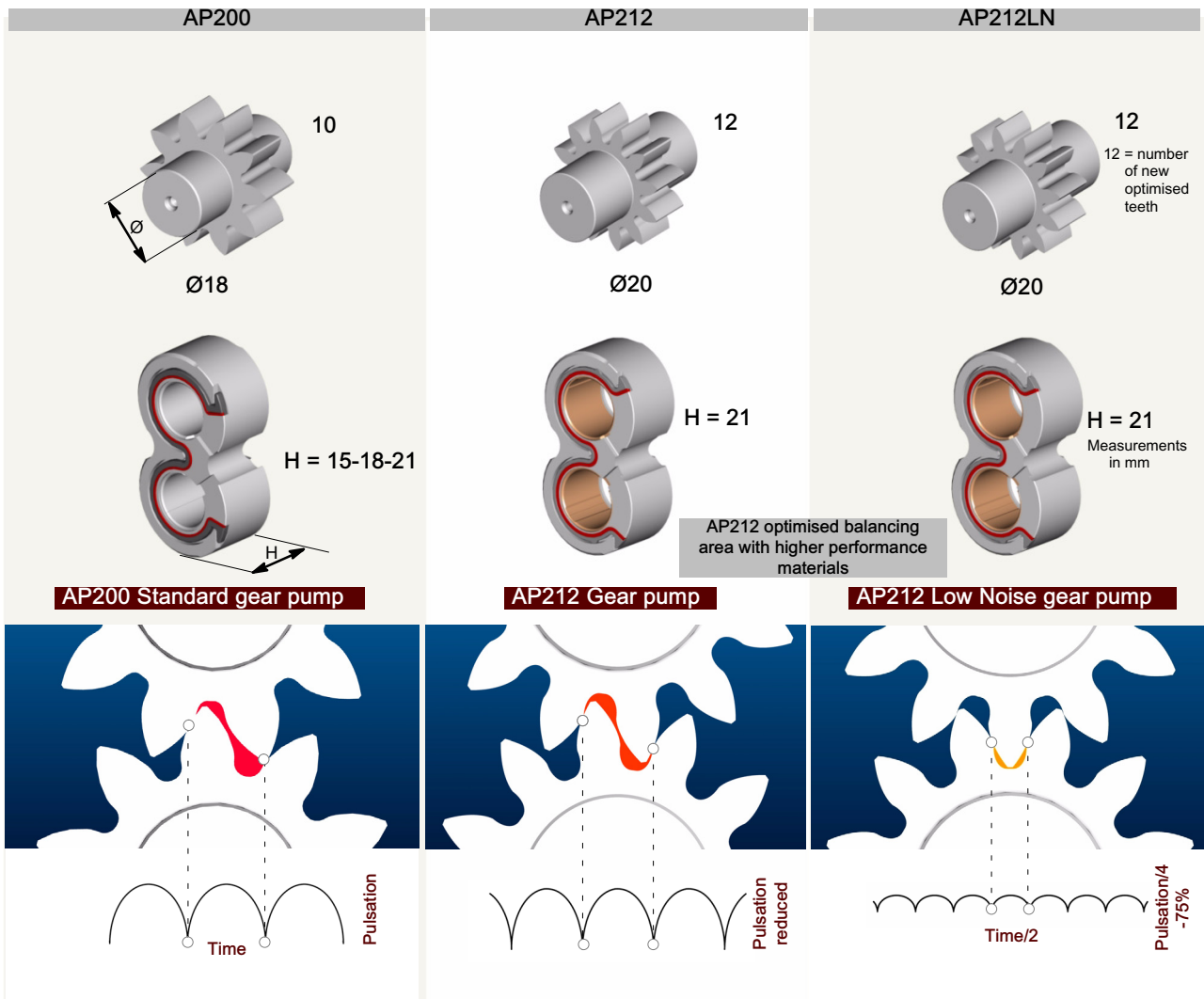

1.2 Example of typical sound pressure level recorded in a semi-anechoic testing room

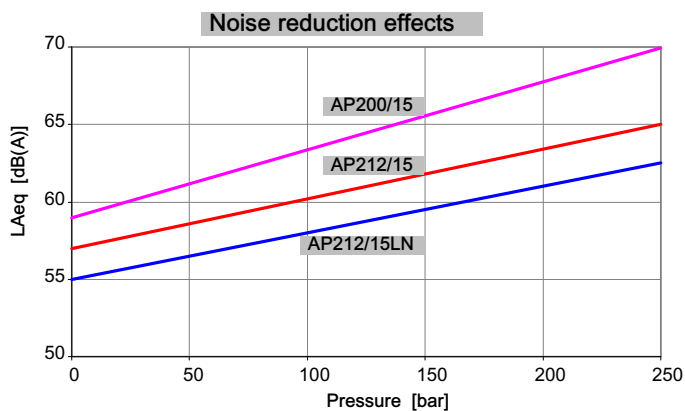

Oil temperature: 40°C - Oil viscosity: 32 mm²/s
Distance between pump and sensor: 1 m



1.3 Technical data

Features	
Operating fluid temperature range (mineral oil): NBR HNBR FPM (VITON)	-15 / +80 °C (peak: -20 / +90 °C) -15 / +100 °C (peak: -20 / +110 °C) -5 / +100 °C (peak: -10 / +110 °C)
Recommended fluids	hydraulic mineral oil-based
Viscosity range: Recommended Permitted Permitted for starting	20-120 mm ² /s (cSt) up to 700 mm ² /s (cSt) 2000 mm ² /s (cSt)
Cleanliness: recommended for operating pressure > 170 bar recommended for operating pressure < 170 bar	21/18/15 ISO 4406 22/19/16 ISO 4406
Standard seals material (valves not included)	NBR + HNBR standard (ISO1629)

Type	AP/APR212 Displacement		AP/APR212LN Displacement		Max. pressure*						n min. P2 < 100 bar rpm	n min. 100 < n < 180 bar rpm	n min. 180 < n < P2 rpm	n max. rpm
	cm ³ /rev	Cu.In. P.R.	cm ³ /rev	Cu.In. P.R.	P1 (continuous)		P2 (intermittent)		P3 (peak)					
					bar	P.S.I.	bar	P.S.I.	bar	P.S.I.				
4.5	4.4	.269	4.5	.275	250	3600	280	4000	300	4300	600	1200	1400	4000
6.5	6.4	.391	6.6	.403	250	3600	280	4000	300	4300	600	1200	1400	4000
8.5	8.4	.513	8.7	.531	250	3600	280	4000	300	4300	600	1000	1400	4000
11	11.1	.677	11.5	.702	250	3600	280	4000	300	4300	500	900	1200	3500
15	15.1	.921	15.7	.958	250	3600	280	4000	300	4300	500	750	1000	3500
19	19.2	1.172	19.8	1.208	210	3000	240	3500	260	3700	500	750	1000	3000
22	22.2	1.355	23	1.404	180	2600	210	3000	230	3300	500	750	900	3000
26	26.2	1.599	27.1	1.654	170	2500	200	2850	220	3150	500	750	1000	2800
22**	22.2	1.355	23	1.404	220	3150	240	3450	260	3700	500	750	900	3000
26**	26.2	1.599	27.1	1.654	200	2850	230	3300	250	3600	500	750	1000	2800

* Referred to pumps and motors with flanged ports. Utilising threaded ports, please to consider a significantly de-rated performances.
The mechanical stress localised on threaded ports cause a reduced pump life performances

** obtained with a specific balancing plate, please contact our Sales Center



IMPORTANT! Please consult Bucher Hydraulics if even one of the operating limits indicated in the table (temperature, pressure, rpm) is exceeded, as well as in the case of two or more maximum values at the same time, or for applications with particularly heavy-duty cycles

1.4 Pressure

Pressure levels:

P1 = continuous pressure

P2 = intermittent pressure

P3 = peak pressure

The recommended oil speed in the pressure pipes is:

v = 2 to 5 m/s

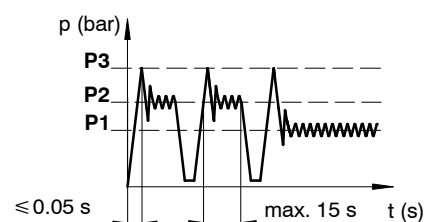

1.5 Suction

The absolute suction pressure must be $P_{in} \geq 0.75$ bar (11 PSI); therefore, the following must be avoided:

- large height differences between pump and tank
- long stretches of piping
- special features such as:
 - bends
 - reductions in diameter
 - quick couplings
 - etc.

It is also advisable to choose a filter of a suitable size to minimise any pressure drop and to take measures to prevent gradual clogging over time.

(Example 1)

In certain cases, the suction pressure can exceed 1 bar (14.3 PSI), or atmospheric pressure.

Please contact our Sales Department, solution for $P_{in} \leq 3.5$ bar (50 PSI), are available.

If in a particular application the P_{in} pressure is higher than the recommended value, contact our Sales Office.

The diameter of the suction pipe should ensure that the oil speed will fall within the range: $v = 0.6 - 1.2$ m/s.

(Example 2)

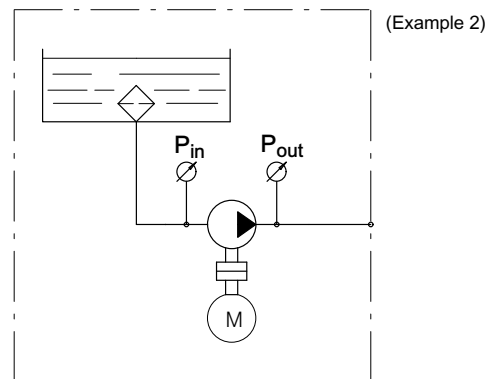
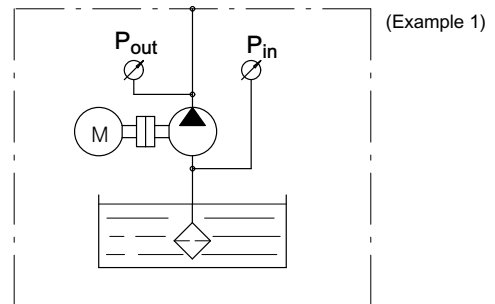

1.6 General precaution

In addition to the recommendations regarding fluids, filtration, coupling, etc., we suggest the following:

- Always check the rotation direction of the pump's drive shaft; it must be compatible with the rotation direction of the pump itself.
- Be particularly careful in cleaning and make sure, when connecting the suction and pressure piping, that no chips, rag threads, teflon tape, etc. get into the pump circulation system.
- Check the tightness of the suction and pressure fittings, the correct positioning of the O-Ring, and make sure there is no dirt between the flange and the pump body.
- The first pump start-up can be facilitated by manually filling the suction piping and the pump itself with oil. To facilitate air bleeding, start the pump with the circuit not pressurised.

- To ensure the best heat distribution inside the tank, make sure the return pipe is not too close to the pump's suction piping. The pipings themselves should be below oil tank level to prevent the formation of foam.
- Do not subject the pumps to operating conditions different from those indicated on section 1.3; for extreme operations, always contact our Technical Department.
- Never use fluids different from those indicated in section 1.3 and do not use fluids incompatible with the pump seals (i.e. HNBR)
- In the event of pump painting, do not use solvents or paints that are incompatible with the material of the seals. Do not bake paint with excessively high temperatures. Do not paint over the product identification plate.

1.6.1 Directives and standards

Atex



Attention: The equipment and protective systems of these catalogue ARE NOT intended for use in potentially explosive atmospheres that is to say where there is an explosive atmosphere referred to in Article 2 of the Directive 99/92/EC and referred to Article 1.3 of the Directive 94/9/EC

Machinery safety

Hydraulic pumps are excluded by Directive 98/37/EC
ISO 9001: 2000

Bucher Hydraulics S.p.A. is certified for research, development and production of directional control valves, gear pumps and motors, power units, electro pumps, cartridge valves and integrated manifolds for hydraulic applications.

1.7 Identifying the rotation direction

The rotation direction of a gear pump is identified by looking at the pump from the front and with the drive gear turned upwards (see figures below).

Pumps with clockwise rotation (D) have a drive gear which turns clockwise, with the suction port on the left and the pressure port on the right.

Pumps with counterclockwise rotation (S) have a drive gear which turns counterclockwise, with the suction port on the right and the pressure port on the left. The figure also shows the pressure flow inside the pumps as the oil is transferred from the suction port to the pressure port.

As regards reversible pumps (R), the ports are alternatively for suction and pressure.

Pumps with a unidirectional rotation (D or S) have the denomination AP.

Pumps with reversible rotation have the denomination APR.

Pumps with "Low Noise" components have the denomination LN.

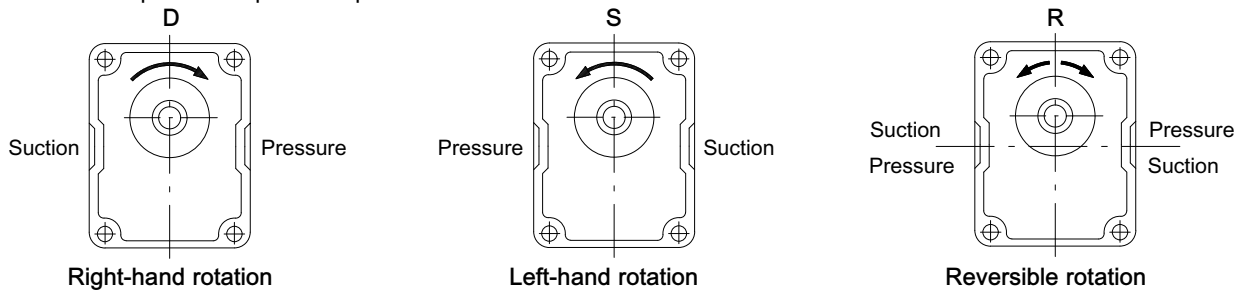

1.8 Motor-pump coupling

Absolutely no radial or axial forces should be transmitted to the drive shaft in the motor-pump coupling.

Such forces cause rapid and irregular wear on the balancing surface of the bushings and gear support, with a consequent worsening in pump performance.

The coupling joint must be able to absorb any discrepancies in the coaxial alignment of the motor-pump shafts without placing any load on the pump shaft.

In the couplings between splined shafts, the connecting sleeve must be free to move along its axis.

The length of the sleeve must be sufficient to cover the splined sections of the motor-pump shafts completely in any position.

A clearance between shaft ends it is necessary.

Make sure that the splined coupling is suitably lubricated to protect it against rapid deterioration.

If there are radial and/or axial loads on the drive shaft, such as when it is driven by a V-belt and pulley or pair of gear wheels, it should be fitted with a front cover with supporting bearings. (See examples 1 and 2)

Depending on the pump model concerned, these supports can replace the front cover of the pump or can be fitted in addition to and over the front cover.

(Example 1)

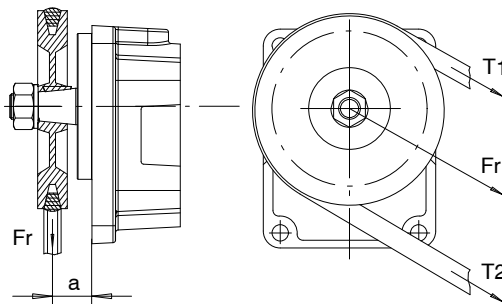

Maximum radial force admitted
1000h

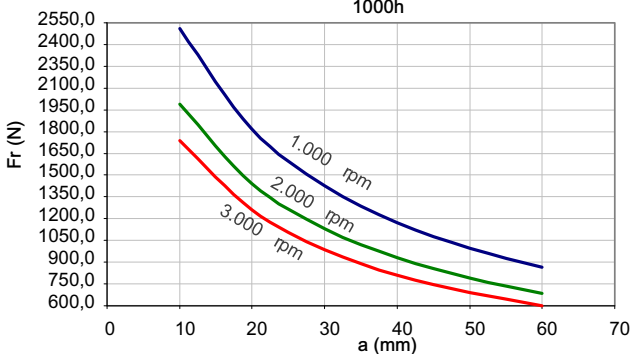

(Example 2)

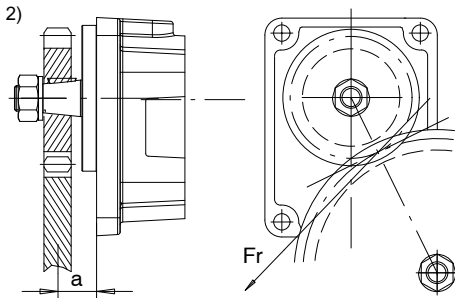

Maximum radial force admitted
5000h

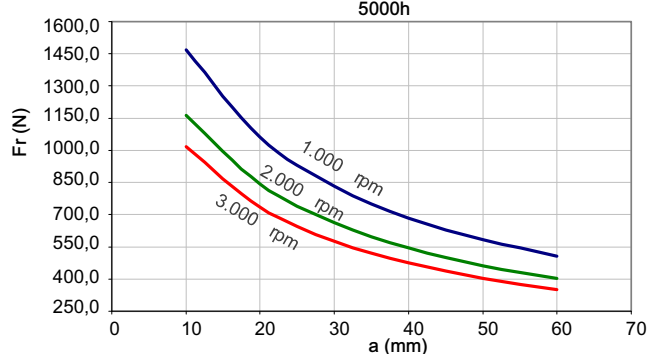

1.9 Non-standard symbols used in the text

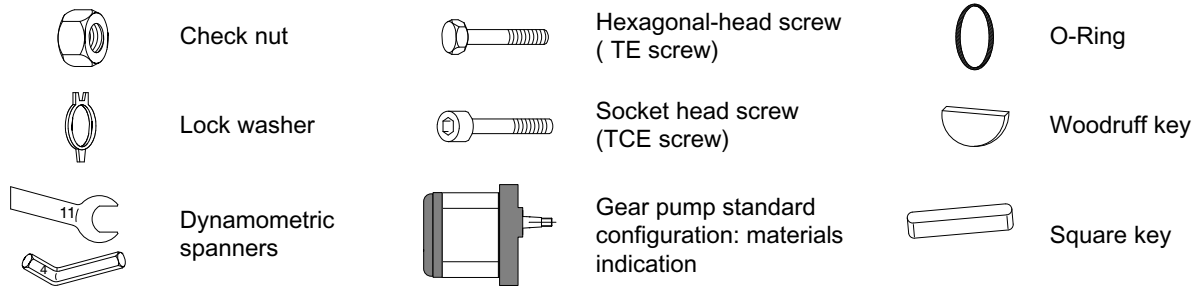

1.10 Calculating the specification of a gear pump

The following parameters are defined:

V_c = (cm³/rev) pump displacement;

n = (rev/min) no. of rpms of the drive shaft;

Q = (l/min) flow rate;

p = (bar) operating pressure;

T = (Nm) drive torque;

N = (kW) Absorbed power;

η_v = (%) volumetric efficiency;

η_m = (%) mechanical efficiency;

η_t = (%) total efficiency

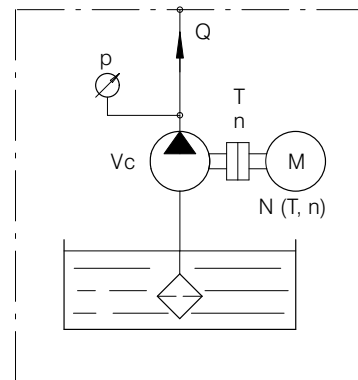

$$Q = \frac{V_c \cdot n}{100000} \cdot \eta_v$$

$$T = 1.59 \cdot \frac{p \cdot V_c}{\eta_m}$$

$$N = \frac{Q \cdot p}{6.12 \cdot \eta_t}$$

Example

AP212/11 $V_c = 11.1 \text{ cm}^3/\text{r}$ $n = 1500 \text{ r/min}$ $p = 200 \text{ bar}$ $\eta_v = 94\%$ $\eta_m = 90\%$ $\eta_t = 84.6\%$

$$Q = \frac{11.1 \cdot 1500}{100000} \cdot 94 = 15.65 \text{ l/min.}$$

$$T = 1.59 \cdot \frac{200 \cdot 11.1}{90} = 39.2 \text{ Nm}$$

$$N = \frac{15.65 \cdot 200}{6.12 \cdot 84.6} = 6.05 \text{ kW}$$

2 Overview standard types

This pumps configuration are considered as "standard".

218	818	225	227	235	245	237	247
259	887S	880	887S-NPTF	880-NPTF	287S-B	280-B	287S-SAEB

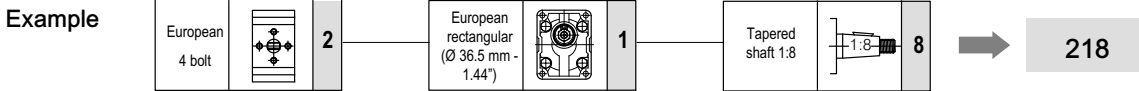





In the next pages, front, rear cover, and seals materials are listed for each pump series. For ordering purposes, it is enough to outline the complete pump description (for example: AP212/4.5 D 218).

In case of a different configuration request (or a combination of different features, such as port threads, front flange materials, etc.), the description configurator shown in section 3.1 can be easily used.

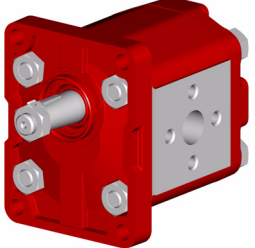
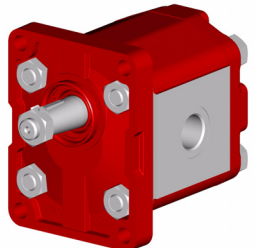
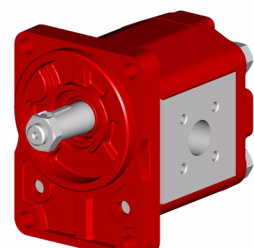
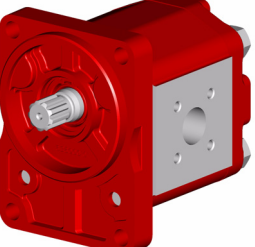
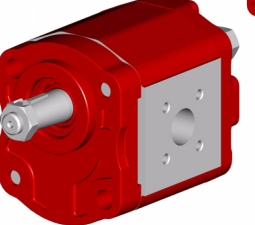
2.1 Standard configuration

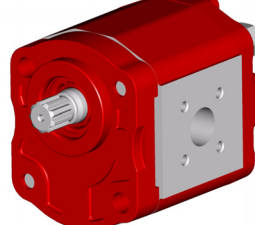
Port type			Aluminium front cover type			Drive shaft		
European 4 bolt flanged		2	European rectangular (Ø 36.5 mm - 1.44")		1	Tapered shaft 1:8		8
German 4 bolt flanged		2	German rectangular (Ø 80 mm - 3.15 inches)		2	Tapered shaft 1:5		5
BSPB Threaded ports		8	Through 2 bolts (Ø 50 mm - 1.97")		3	Tang drive 8 mm - 0.32 inches		9
SAE Threaded ports		8	Through 2 bolts (Ø 50 mm - 1.97")		4	9 Teeth external spline B17X14 DIN5482		7
NPTF Threaded ports		8	Through 2 bolts (Ø 52 mm - 2.045")		5	9 teeth external spline SAE J 498-9T 16/32 DP		7S
			SAE-A 2 bolts (Ø 82.55 mm - 3.25 inches)		8	Straight keyed Ø 15.85 mm - 0.62 inches		0
			Cast iron front cover type					
			SAE-B 2 bolts (Ø 101,6 mm - 4 inches)		8			

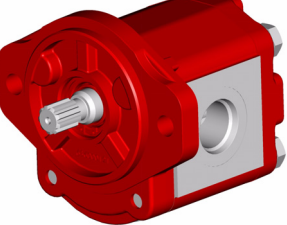
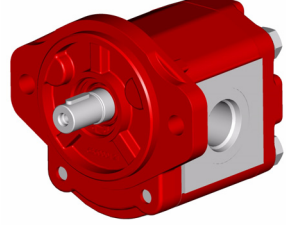
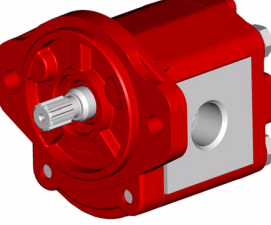
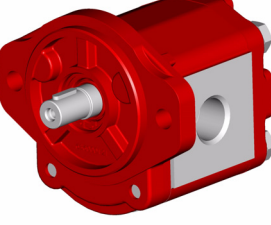
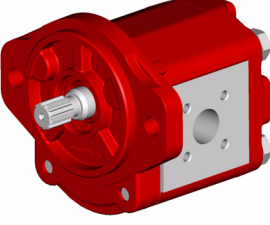
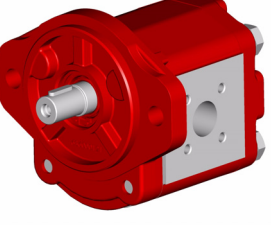
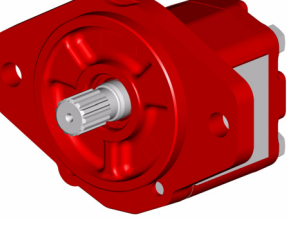
Serie	page	Serie	page	Serie	page
218	12	818	13	225	14
					
227	15	235 - 245	16 17	237 - 247	18 19
		 		 	
259	20	887S	21	880	22
					
887S-NPTF	23	880-NPTF	24	287S-B	25
					
280-B	26	287S-SAEB	27		
					

For reversible pumps alternative inlet and outlet ports have the same sizes as per inlet unidirectional rotation.

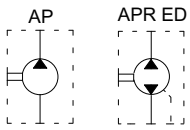

**Serie
218**

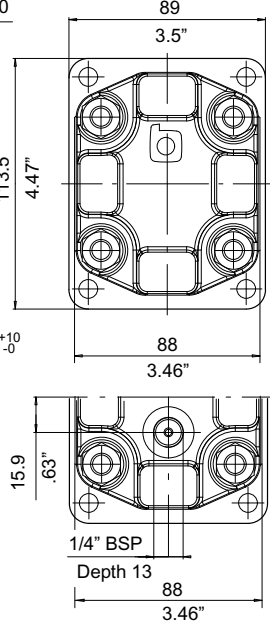
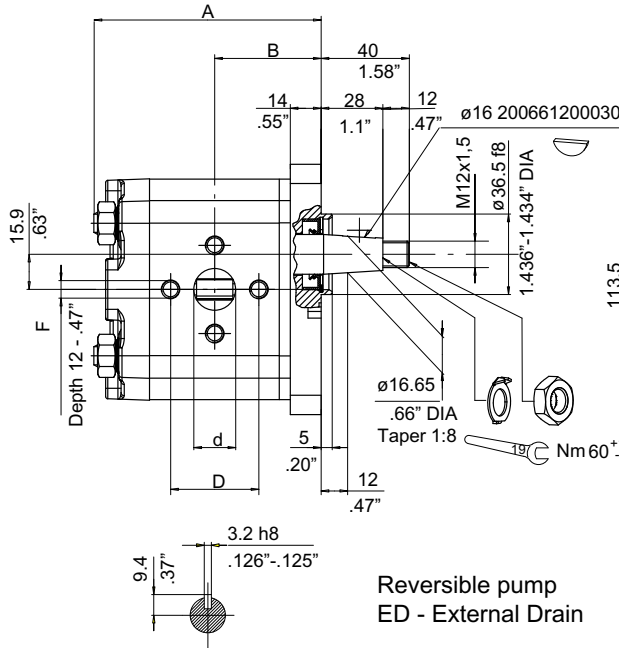
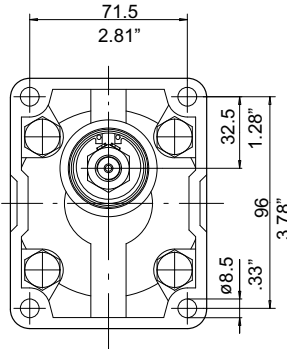
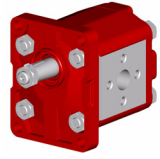

Gear pump material	
Front cover: aluminium	
Body: aluminium	
Back cover: cast iron	
Seals: NBR + HNBR	

Reversible pump
ED - External Drain

Tightening torque: see section 3.6
Shaft max torque: see section 3.3

Type	Displacement cm ³ /rev		Dimensions				Suction					Pressure				
	AP212	AP212LN	mm	inch	mm	inch	d	D	F	d	D	F	d	D	F	
4.5	4.4	4.5	94	3.70	43.3	1.70	13.5	.53	30	1.18	M6X1	13.5	.53	30	1.18	M6X1
6.5	6.4	6.6	97	3.82	44.8	1.76										
8.5	8.4	8.7	100	3.94	46.3	1.82										
11	11.1	11.5	104	4.09	48.3	1.90										
15	15.1	15.7	110	4.33	51.3	2.02	19	.75	40	1.58	M8X1.25	19	.75	40	1.58	M8X1.25
19	19.2	19.8	114	4.49	54.3	2.14										
22	22.2	23	118	4.65	56.5	2.22										
26	26.2	27.1	124	4.88	59.5	2.34										

Clockwise rotation: D		Counter-clockwise rotation: S		Reversible pump External Drain	
Standard	Low Noise	Standard	Low Noise	Standard	Low Noise
AP212/4.5 D 218	AP212/4.5LN D 218	AP212/4.5 S 218	AP212/4.5LN S 218	APR212/4.5 ED 218	APR212/4.5LN ED 218
AP212/6.5 D 218	AP212/6.5LN D 218	AP212/6.5 S 218	AP212/6.5LN S 218	APR212/6.5 ED 218	APR212/6.5LN ED 218
AP212/8.5 D 218	AP212/8.5LN D 218	AP212/8.5 S 218	AP212/8.5LN S 218	APR212/8.5 ED 218	APR212/8.5LN ED 218
AP212/11 D 218	AP212/11LN D 218	AP212/11 S 218	AP212/11LN S 218	APR212/11 ED 218	APR212/11LN ED 218
AP212/15 D 218	AP212/15LN D 218	AP212/15 S 218	AP212/15LN S 218	APR212/15 ED 218	APR212/15LN ED 218
AP212/19 D 218	AP212/19LN D 218	AP212/19 S 218	AP212/19LN S 218	APR212/19 ED 218	APR212/19LN ED 218
AP212/22 D 218	AP212/22LN D 218	AP212/22 S 218	AP212/22LN S 218	APR212/22 ED 218	APR212/22LN ED 218
AP212/26 D 218	AP212/26LN D 218	AP212/26 S 218	AP212/26LN S 218	APR212/26 ED 218	APR212/26LN ED 218

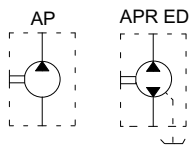

Serie
818

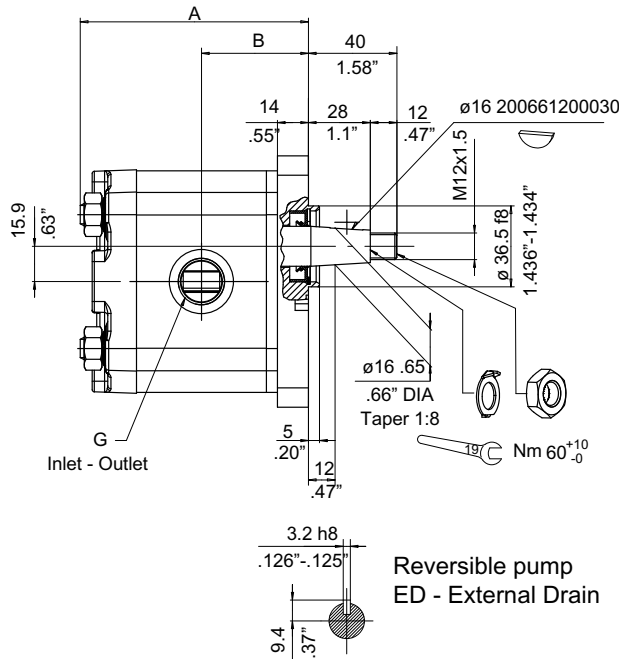
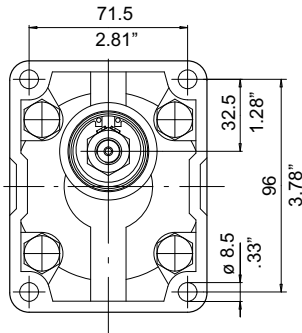
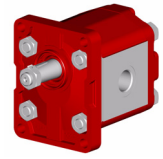

Gear pump material	
Front cover:	aluminium
Body:	aluminium
Back cover:	cast iron
Seals:	NBR + HNBR

Tightening torque: see section 3.5 -3.6
Shaft max torque: see section 3.3

Type	Displacement cm ³ /rev		Dimensions				Suction	Pressure
	AP212	AP212LN	A		B		G	G
			mm	inch	mm	inch	BSP	BSP
4.5	4.4	4.5	94	3.70	43.3	1.70	3/8"	3/8"
6.5	6.4	6.6	97	3.82	44.8	1.76		
8.5	8.4	8.7	100	3.94	46.3	1.82		
11	11.1	11.5	104	4.09	48.3	1.90	1/2"	
15	15.1	15.7	110	4.33	51.3	2.02		
19	19.2	19.8	114	4.49	54.3	2.14	3/4"	1/2"
22	22.2	23	118	4.65	56.5	2.22		
26	26.2	27.1	124	4.88	59.5	2.34		

Clockwise rotation: D		Counter-clockwise rotation: S		Reversible pump External Drain	
Standard	Low Noise	Standard	Low Noise	Standard	Low Noise
AP212/4.5 D 818	AP212/4.5LN D 818	AP212/4.5 S 818	AP212/4.5LN S 818	APR212/4.5 ED 818	APR212/4.5LN ED 818
AP212/6.5 D 818	AP212/6.5LN D 818	AP212/6.5 S 818	AP212/6.5LN S 818	APR212/6.5 ED 818	APR212/6.5LN ED 818
AP212/8.5 D 818	AP212/8.5LN D 818	AP212/8.5 S 818	AP212/8.5LN S 818	APR212/8.5 ED 818	APR212/8.5LN ED 818
AP212/11 D 818	AP212/11LN D 818	AP212/11 S 818	AP212/11LN S 818	APR212/11 ED 818	APR212/11LN ED 818
AP212/15 D 818	AP212/15LN D 818	AP212/15 S 818	AP212/15LN S 818	APR212/15 ED 818	APR212/15LN ED 818
AP212/19 D 818	AP212/19LN D 818	AP212/19 S 818	AP212/19LN S 818	APR212/19 ED 818	APR212/19LN ED 818
AP212/22 D 818	AP212/22LN D 818	AP212/22 S 818	AP212/22LN S 818	APR212/22 ED 818	APR212/22LN ED 818
AP212/26 D 818	AP212/26LN D 818	AP212/26 S 818	AP212/26LN S 818	APR212/26 ED 818	APR212/26LN ED 818

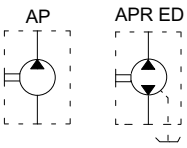

Serie
225

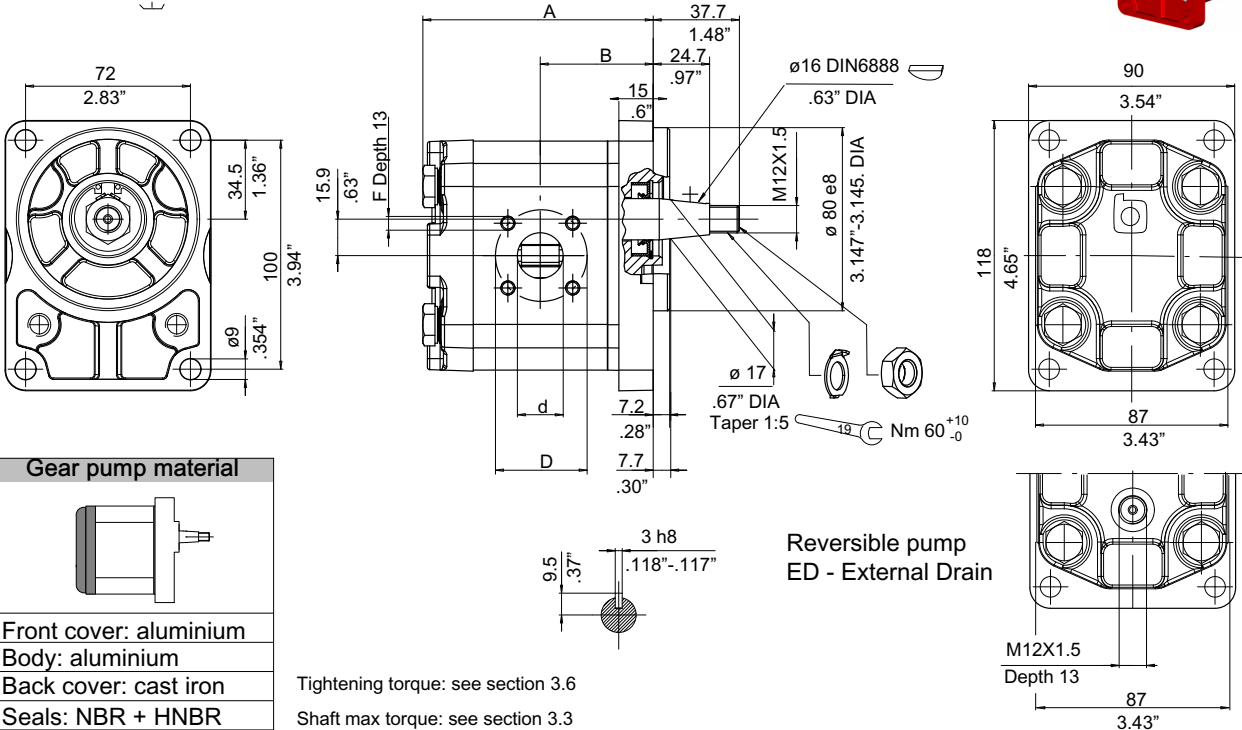
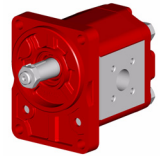

Gear pump material

Front cover: aluminium
Body: aluminium
Back cover: cast iron
Seals: NBR + HNBR

Type	Displacement cm ³ /rev		Dimensions				Suction				Pressure					
	AP212	AP212LN	A mm	inch	B mm	inch	d mm	inch	D mm	inch	F mm	d mm	inch	D mm	inch	F mm
4.5	4.4	4.5	91	3.85	44.3	1.74	15	.59	40	1.58	M6X1	15	.59	35	1.38	M6X1
6.5	6.4	6.6	94	3.70	45.8	1.80										
8.5	8.4	8.7	97	3.82	47.3	1.86										
11	11.1	11.5	101	3.98	49.3	1.94	20	.79	40	1.58	M6X1	15	.59	35	1.38	M6X1
15	15.1	15.7	107	4.21	52.3	2.06										
19	19.2	19.8	113	4.45	55.3	2.18										
22	22.2	23	117	4.61	57.5	2.26										
26	26.2	27.1	123	4.84	60.5	2.38										

Clockwise rotation: D		Counter-clockwise rotation: S		Reversible pump External Drain	
Standard	Low Noise	Standard	Low Noise	Standard	Low Noise
AP212/4.5 D 225	AP212/4.5LN D 225	AP212/4.5 S 225	AP212/4.5LN S 225	APR212/4.5 ED 225	APR212/4.5LN ED 225
AP212/6.5 D 225	AP212/6.5LN D 225	AP212/6.5 S 225	AP212/6.5LN S 225	APR212/6.5 ED 225	APR212/6.5LN ED 225
AP212/8.5 D 225	AP212/8.5LN D 225	AP212/8.5 S 225	AP212/8.5LN S 225	APR212/8.5 ED 225	APR212/8.5LN ED 225
AP212/11 D 225	AP212/11LN D 225	AP212/11 S 225	AP212/11LN S 225	APR212/11 ED 225	APR212/11LN ED 225
AP212/15 D 225	AP212/15LN D 225	AP212/15 S 225	AP212/15LN S 225	APR212/15 ED 225	APR212/15LN ED 225
AP212/19 D 225	AP212/19LN D 225	AP212/19 S 225	AP212/19LN S 225	APR212/19 ED 225	APR212/19LN ED 225
AP212/22 D 225	AP212/22LN D 225	AP212/22 S 225	AP212/22LN S 225	APR212/22 ED 225	APR212/22LN ED 225
AP212/26 D 225	AP212/26LN D 225	AP212/26 S 225	AP212/26LN S 225	APR212/26 ED 225	APR212/26LN ED 225

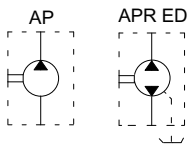

Serie
227

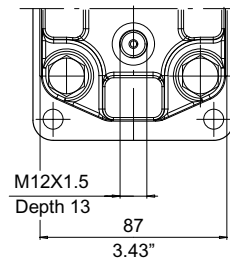
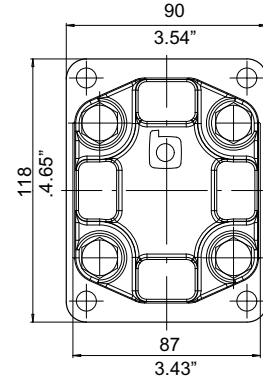
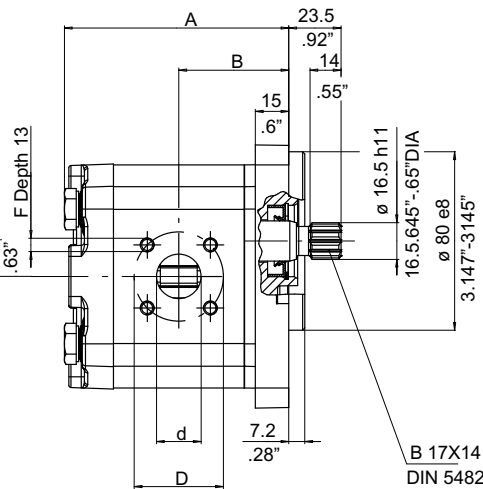
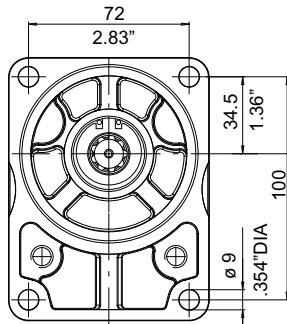
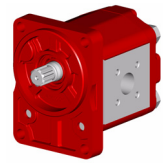

Reversible pump
ED - External Drain

Gear pump material	
Front cover:	aluminium
Body:	aluminium
Back cover:	cast iron
Seals:	NBR + HNBR

Tightening torque: see section 3.6
Shaft max torque: see section 3.3

Type	Displacement cm ³ /rev		Dimensions				Suction			Pressure						
	AP212	AP212LN	A mm	inch	B mm	inch	d mm	inch	D mm	inch	F mm	d mm	inch	D mm	inch	F mm
4.5	4.4	4.5	91	3.85	44.3	1.74	15	.59	40	1.58	M6X1	15	.59	35	1.38	M6X1
6.5	6.4	6.6	94	3.70	45.8	1.80										
8.5	8.4	8.7	97	3.82	47.3	1.86										
11	11.1	11.5	101	3.98	49.3	1.94	20	.79	40	1.58	M6X1	15	.59	35	1.38	M6X1
15	15.1	15.7	107	4.21	52.3	2.06										
19	19.2	19.8	113	4.45	55.3	2.18										
22	22.2	23	117	4.61	57.5	2.26										
26	26.2	27.1	123	4.84	60.5	2.38										

Clockwise rotation: D		Counter-clockwise rotation: S		Reversible pump External Drain	
Standard	Low Noise	Standard	Low Noise	Standard	Low Noise
AP212/4.5 D 227	AP212/4.5LN D 227	AP212/4.5 S 227	AP212/4.5LN S 227	APR212/4.5 ED 227	APR212/4.5LN ED 227
AP212/6.5 D 227	AP212/6.5LN D 227	AP212/6.5 S 227	AP212/6.5LN S 227	APR212/6.5 ED 227	APR212/6.5LN ED 227
AP212/8.5 D 227	AP212/8.5LN D 227	AP212/8.5 S 227	AP212/8.5LN S 227	APR212/8.5 ED 227	APR212/8.5LN ED 227
AP212/11 D 227	AP212/11LN D 227	AP212/11 S 227	AP212/11LN S 227	APR212/11 ED 227	APR212/11LN ED 227
AP212/15 D 227	AP212/15LN D 227	AP212/15 S 227	AP212/15LN S 227	APR212/15 ED 227	APR212/15LN ED 227
AP212/19 D 227	AP212/19LN D 227	AP212/19 S 227	AP212/19LN S 227	APR212/19 ED 227	APR212/19LN ED 227
AP212/22 D 227	AP212/22LN D 227	AP212/22 S 227	AP212/22LN S 227	APR212/22 ED 227	APR212/22LN ED 227
AP212/26 D 227	AP212/26LN D 227	AP212/26 S 227	AP212/26LN S 227	APR212/26 ED 227	APR212/26LN ED 227

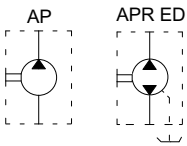

Serie
235

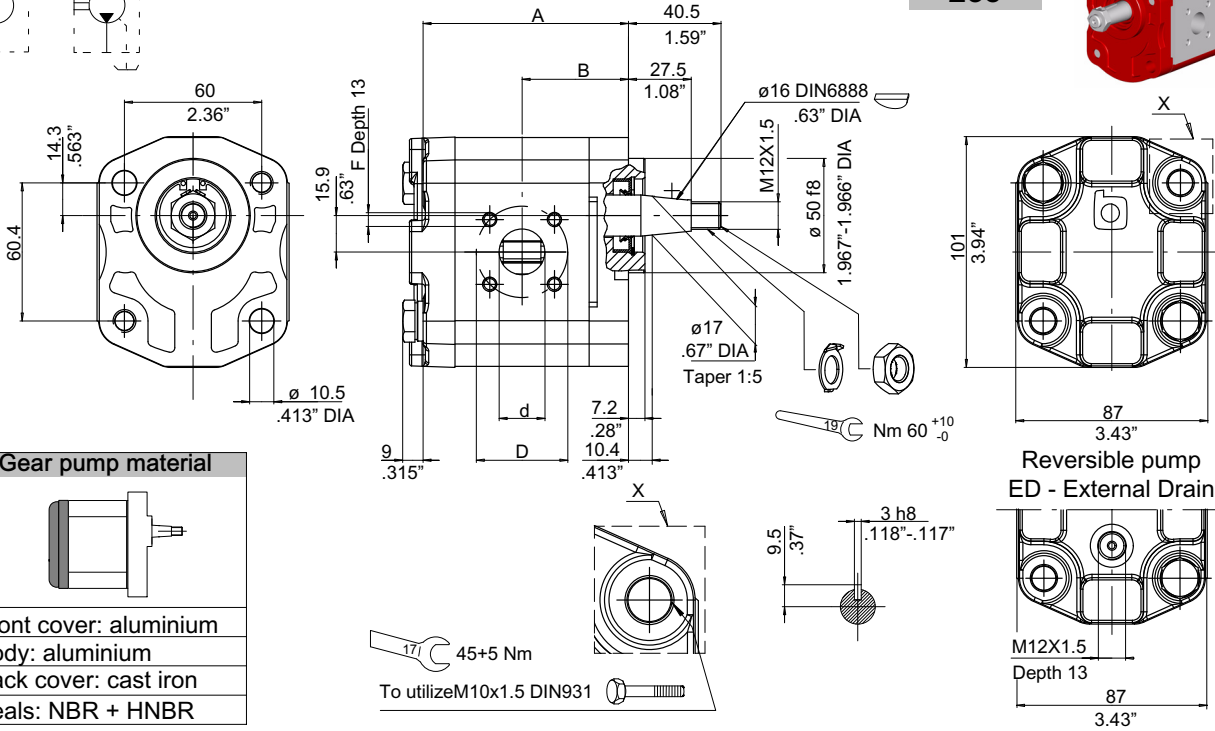
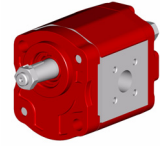

Gear pump material

Front cover: aluminium
Body: aluminium
Back cover: cast iron
Seals: NBR + HNBR

Shaft max torque: see section 3.3

Tightening torque: see section 3.6

Type	Displacement cm ³ /rev		Dimensions				Suction				Pressure					
	AP212	AP212LN	A mm	A inch	B mm	B inch	d mm	d inch	D mm	D inch	F mm	d mm	d inch	D mm	D inch	F mm
4.5	4.4	4.5	80	3.15	41.5	1.63	15	.59	40	1.58	M6X1	15	.59	35	1.38	M6X1
6.5	6.4	6.6	83	3.27	43	1.69										
8.5	8.4	8.7	86	3.39	44.5	1.75										
11	11.1	11.5	90	3.54	46.5	1.83	20	.79	40	1.58	M6X1	15	.59	35	1.38	M6X1
15	15.1	15.7	96	3.78	49.5	1.95										
19	19.2	19.8	102	4.02	52.5	2.07										
22	22.2	23	106	4.17	54.8	2.16										
26	26.2	27.1	112	4.41	57.8	2.28										

Clockwise rotation: D		Counter-clockwise rotation: S		Reversible pump External Drain	
Standard	Low Noise	Standard	Low Noise	Standard	Low Noise
AP212/4.5 D 235	AP212/4.5LN D 235	AP212/4.5 S 235	AP212/4.5LN S 235	APR212/4.5 ED 235	APR212/4.5LN ED 235
AP212/6.5 D 235	AP212/6.5LN D 235	AP212/6.5 S 235	AP212/6.5LN S 235	APR212/6.5 ED 235	APR212/6.5LN ED 235
AP212/8.5 D 235	AP212/8.5LN D 235	AP212/8.5 S 235	AP212/8.5LN S 235	APR212/8.5 ED 235	APR212/8.5LN ED 235
AP212/11 D 235	AP212/11LN D 235	AP212/11 S 235	AP212/11LN S 235	APR212/11 ED 235	APR212/11LN ED 235
AP212/15 D 235	AP212/15LN D 235	AP212/15 S 235	AP212/15LN S 235	APR212/15 ED 235	APR212/15LN ED 235
AP212/19 D 235	AP212/19LN D 235	AP212/19 S 235	AP212/19LN S 235	APR212/19 ED 235	APR212/19LN ED 235
AP212/22 D 235	AP212/22LN D 235	AP212/22 S 235	AP212/22LN S 235	APR212/22 ED 235	APR212/22LN ED 235
AP212/26 D 235	AP212/26LN D 235	AP212/26 S 235	AP212/26LN S 235	APR212/26 ED 235	APR212/26LN ED 235

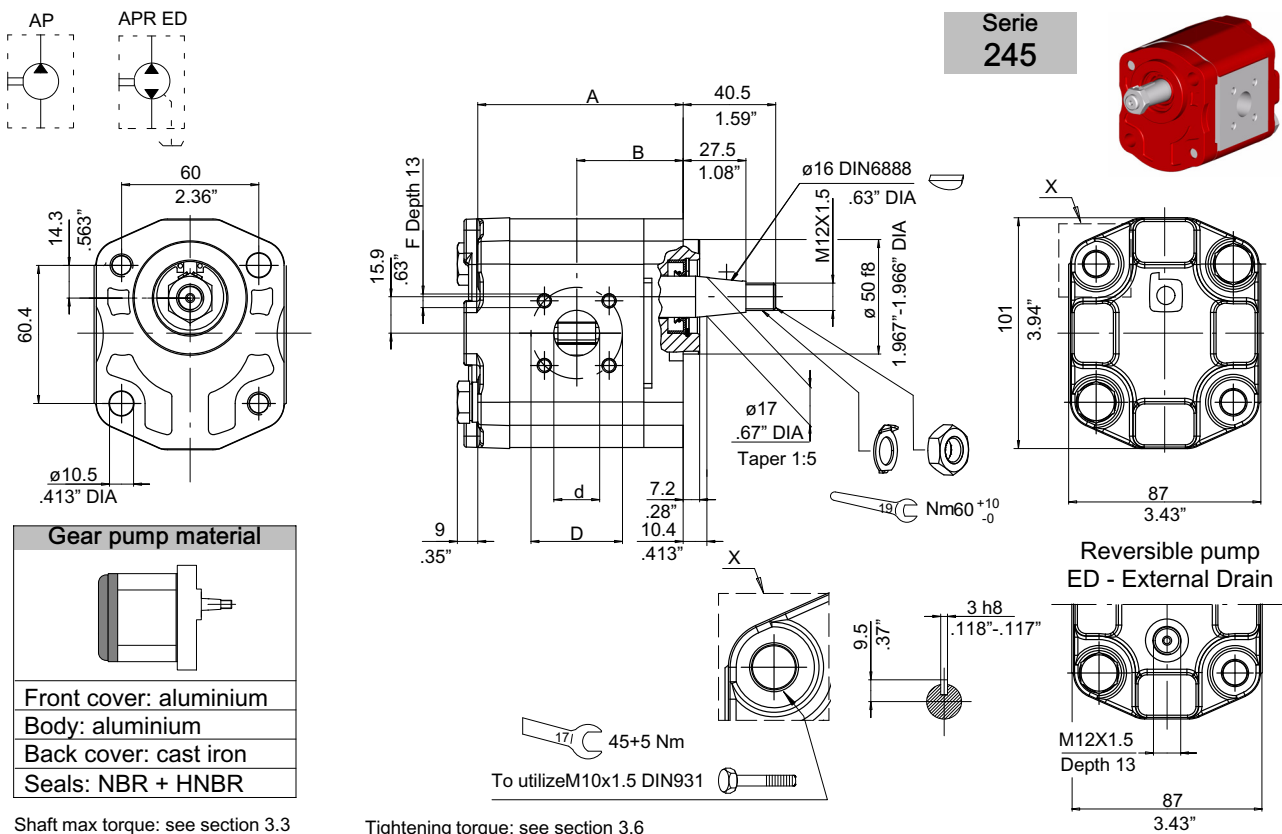

Type	Displacement cm ³ /rev		Dimensions				Suction				Pressure			
	AP212	AP212LN	mm	inch	mm	inch	d	D	F	d	D	F	d	D
4.5	4.4	4.5	80	3.15	41.5	1.63	15	.59	M6X1	15	.59	35	1.38	M6X1
6.5	6.4	6.6	83	3.27	43	1.69								
8.5	8.4	8.7	86	3.39	44.5	1.75								
11	11.1	11.5	90	3.54	46.5	1.83	20	.79	M6X1	15	.59	35	1.38	M6X1
15	15.1	15.7	96	3.78	49.5	1.95								
19	19.2	19.8	102	4.02	52.5	2.07								
22	22.2	23	106	4.17	54.8	2.16								
26	26.2	27.1	112	4.41	57.8	2.28								

Clockwise rotation: D		Counter-clockwise rotation: S		Reversible pump External Drain	
Standard	Low Noise	Standard	Low Noise	Standard	Low Noise
AP212/4.5 D 245	AP212/4.5LN D 245	AP212/4.5 S 245	AP212/4.5LN S 245	APR212/4.5 ED 245	APR212/4.5LN ED 245
AP212/6.5 D 245	AP212/6.5LN D 245	AP212/6.5 S 245	AP212/6.5LN S 245	APR212/6.5 ED 245	APR212/6.5LN ED 245
AP212/8.5 D 245	AP212/8.5LN D 245	AP212/8.5 S 245	AP212/8.5LN S 245	APR212/8.5 ED 245	APR212/8.5LN ED 245
AP212/11 D 245	AP212/11LN D 245	AP212/11 S 245	AP212/11LN S 245	APR212/11 ED 245	APR212/11LN ED 245
AP212/15 D 245	AP212/15LN D 245	AP212/15 S 245	AP212/15LN S 245	APR212/15 ED 245	APR212/15LN ED 245
AP212/19 D 245	AP212/19LN D 245	AP212/19 S 245	AP212/19LN S 245	APR212/19 ED 245	APR212/19LN ED 245
AP212/22 D 245	AP212/22LN D 245	AP212/22 S 245	AP212/22LN S 245	APR212/22 ED 245	APR212/22LN ED 245
AP212/26 D 245	AP212/26LN D 245	AP212/26 S 245	AP212/26LN S 245	APR212/26 ED 245	APR212/26LN ED 245

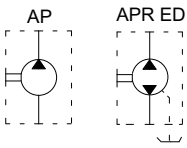

Serie
237

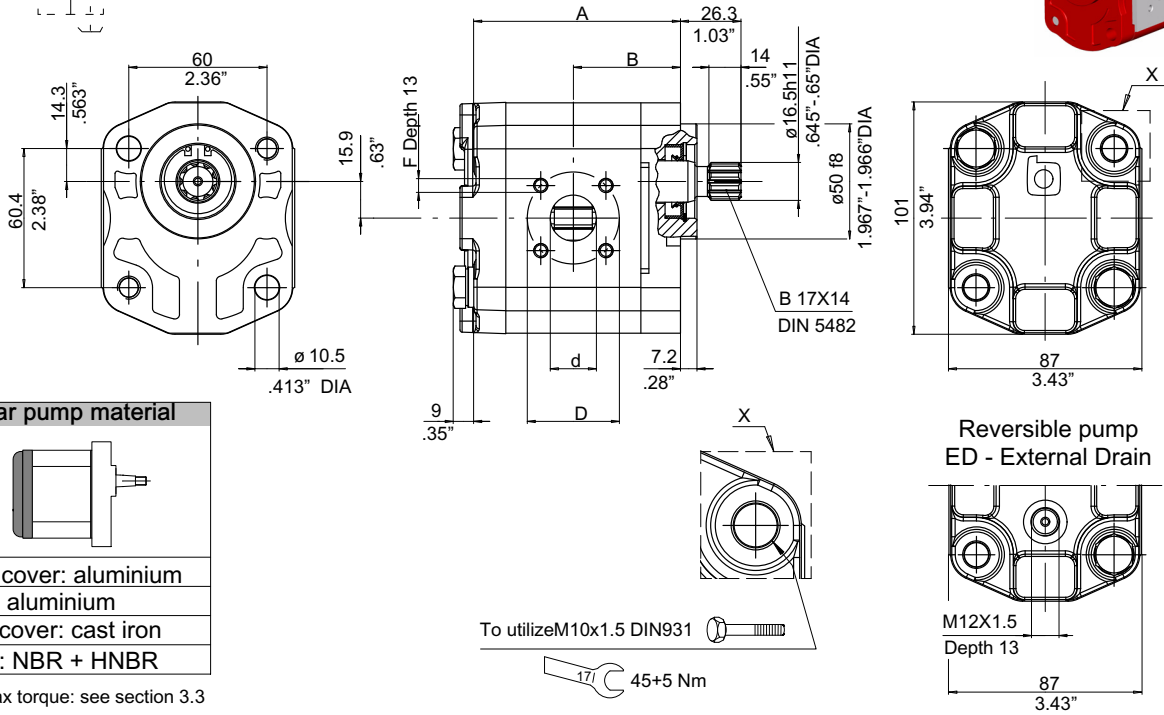

Gear pump material

Front cover: aluminium
Body: aluminium
Back cover: cast iron
Seals: NBR + HNBR

Shaft max torque: see section 3.3
Tightening torque: see section 3.6

Type	Displacement cm ³ /rev		Dimensions				Suction			Pressure						
	AP212	AP212LN	A		B		d		D		F	d		D		F
			mm	inch	mm	inch	mm	inch	mm	inch	mm	mm	inch	mm	inch	mm
4.5	4.4	4.5	80	3.15	41.5	1.63	15	.59	40	1.58	M6X1	15	.59	35	1.38	M6X1
6.5	6.4	6.6	83	3.27	43	1.69										
8.5	8.4	8.7	86	3.39	44.5	1.75										
11	11.1	11.5	90	3.54	46.5	1.83	20	.79	40	1.58	M6X1	15	.59	35	1.38	M6X1
15	15.1	15.7	96	3.78	49.5	1.95										
19	19.2	19.8	102	4.02	52.5	2.07										
22	22.2	23	106	4.17	54.8	2.16										
26	26.2	27.1	112	4.41	57.8	2.28										

Clockwise rotation: D		Counter-clockwise rotation: S		Reversible pump External Drain	
Standard	Low Noise	Standard	Low Noise	Standard	Low Noise
AP212/4.5 D 237	AP212/4.5LN D 237	AP212/4.5 S 237	AP212/4.5LN S 237	APR212/4.5 ED 237	APR212/4.5LN ED 237
AP212/6.5 D 237	AP212/6.5LN D 237	AP212/6.5 S 237	AP212/6.5LN S 237	APR212/6.5 ED 237	APR212/6.5LN ED 237
AP212/8.5 D 237	AP212/8.5LN D 237	AP212/8.5 S 237	AP212/8.5LN S 237	APR212/8.5 ED 237	APR212/8.5LN ED 237
AP212/11 D 237	AP212/11LN D 237	AP212/11 S 237	AP212/11LN S 237	APR212/11 ED 237	APR212/11LN ED 237
AP212/15 D 237	AP212/15LN D 237	AP212/15 S 237	AP212/15LN S 237	APR212/15 ED 237	APR212/15LN ED 237
AP212/19 D 237	AP212/19LN D 237	AP212/19 S 237	AP212/19LN S 237	APR212/19 ED 237	APR212/19LN ED 237
AP212/22 D 237	AP212/22LN D 237	AP212/22 S 237	AP212/22LN S 237	APR212/22 ED 237	APR212/22LN ED 237
AP212/26 D 237	AP212/26LN D 237	AP212/26 S 237	AP212/26LN S 237	APR212/26 ED 237	APR212/26LN ED 237

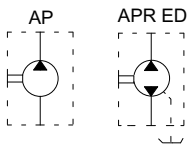

Serie
247

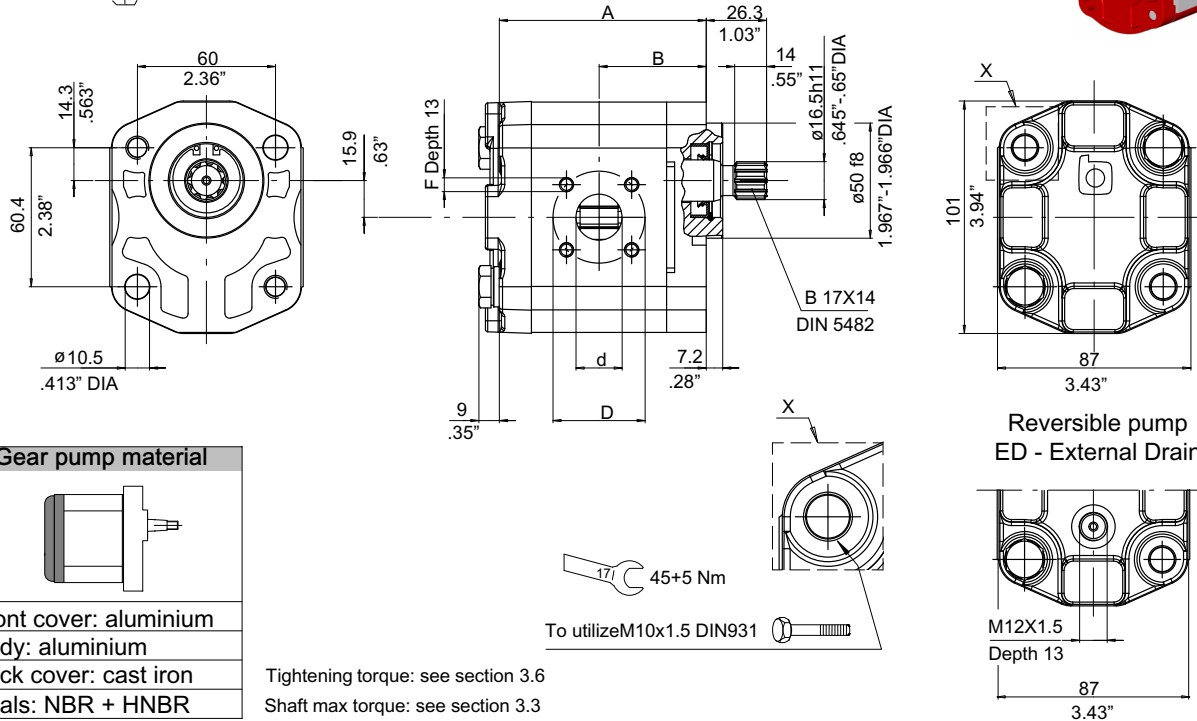
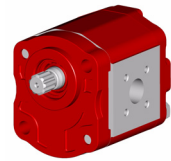

Type	Displacement cm ³ /rev		Dimensions				Suction			Pressure						
	AP212	AP212LN	A mm	inch	B mm	inch	d mm	inch	D mm	inch	F mm	d mm	inch	D mm	inch	F mm
4.5	4.4	4.5	80	3.15	41.5	1.63	15	.59	40	1.58	M6X1	15	.59	35	1.38	M6X1
6.5	6.4	6.6	83	3.27	43	1.69										
8.5	8.4	8.7	86	3.39	44.5	1.75										
11	11.1	11.5	90	3.54	46.5	1.83	20	.79	40	1.58	M6X1	15	.59	35	1.38	M6X1
15	15.1	15.7	96	3.78	49.5	1.95										
19	19.2	19.8	102	4.02	52.5	2.07										
22	22.2	23	106	4.17	54.8	2.16										
26	26.2	27.1	112	4.41	57.8	2.28										

Clockwise rotation: D		Counter-clockwise rotation: S		Reversible pump External Drain	
Standard	Low Noise	Standard	Low Noise	Standard	Low Noise
AP212/4.5 D 247	AP212/4.5LN D 247	AP212/4.5 S 247	AP212/4.5LN S 247	APR212/4.5 ED 247	APR212/4.5LN ED 247
AP212/6.5 D 247	AP212/6.5LN D 247	AP212/6.5 S 247	AP212/6.5LN S 247	APR212/6.5 ED 247	APR212/6.5LN ED 247
AP212/8.5 D 247	AP212/8.5LN D 247	AP212/8.5 S 247	AP212/8.5LN S 247	APR212/8.5 ED 247	APR212/8.5LN ED 247
AP212/11 D 247	AP212/11LN D 247	AP212/11 S 247	AP212/11LN S 247	APR212/11 ED 247	APR212/11LN ED 247
AP212/15 D 247	AP212/15LN D 247	AP212/15 S 247	AP212/15LN S 247	APR212/15 ED 247	APR212/15LN ED 247
AP212/19 D 247	AP212/19LN D 247	AP212/19 S 247	AP212/19LN S 247	APR212/19 ED 247	APR212/19LN ED 247
AP212/22 D 247	AP212/22LN D 247	AP212/22 S 247	AP212/22LN S 247	APR212/22 ED 247	APR212/22LN ED 247
AP212/26 D 247	AP212/26LN D 247	AP212/26 S 247	AP212/26LN S 247	APR212/26 ED 247	APR212/26LN ED 247

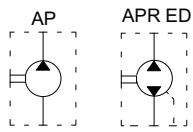

Serie
259

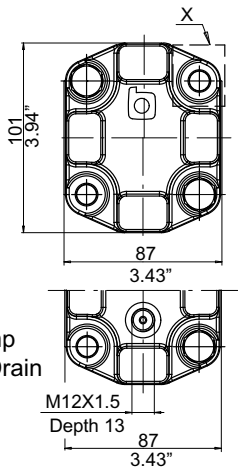
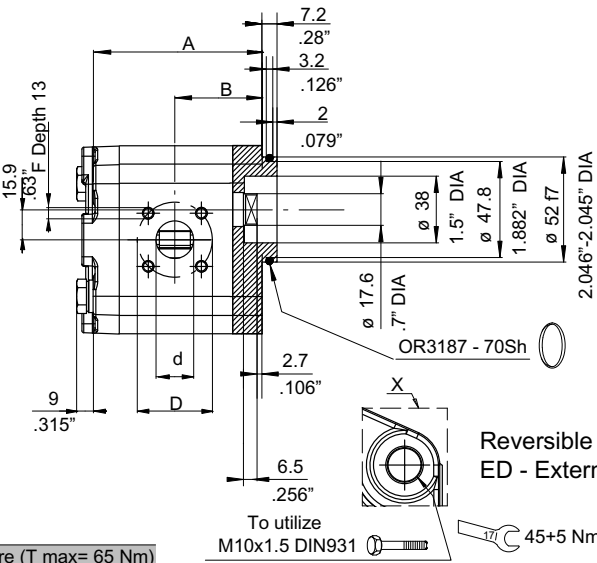
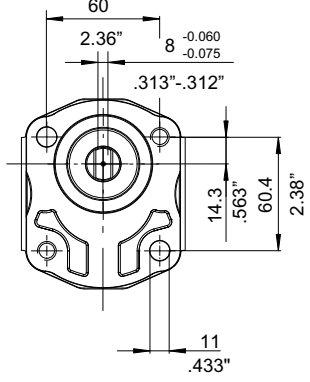

Tightening torque: see section 3.6
Shaft max torque: see section 3.3

Gear pump material

Front cover: aluminium
Body: aluminium
Back cover: cast iron
Seals: NBR + HNBR

Pump	Max pressure (T max= 65 Nm)		
	P1	P2	P3
AP212/15	180 (2600)	210 (3000)	230 (3300)
AP212/19	140 (2000)	165 (2400)	185 (2650)
AP212/22	120 (1700)	145 (2050)	165 (2350)
AP212/26	100 (1450)	120 (1750)	140 (2000)

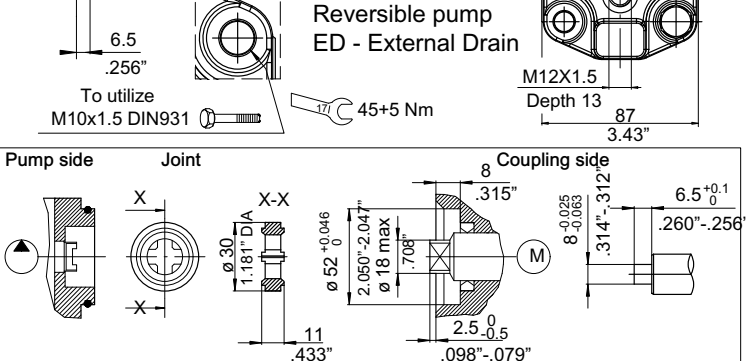

Type	Displacement		Dimensions				Suction				Pressure					
	cm ³ /rev		A		B		d		D		d		D		F	
	AP212	AP212LN	mm	inch	mm	inch	mm	inch	mm	inch	mm	inch	mm	inch	mm	
4.5	4.4	4.5	80	3.15	41.5	1.63										
6.5	6.4	6.6	83	3.27	43	1.69	15	.59								
8.5	8.4	8.7	86	3.39	44.5	1.75										
11	11.1	11.5	90	3.54	46.5	1.83										
15	15.1	15.7	96	3.78	49.5	1.95			40	1.58	M6X1	15	.59	35	1.38	M6X1
19	19.2	19.8	102	4.02	52.5	2.07										
22	22.2	23	106	4.17	54.8	2.16										
26	26.2	27.1	112	4.41	57.8	2.28	20	.79								

Clockwise rotation: D		Counter-clockwise rotation: S		Reversible pump External Drain	
Standard	Low Noise	Standard	Low Noise	Standard	Low Noise
AP212/4.5 D 259	AP212/4.5LN D 259	AP212/4.5 S 259	AP212/4.5LN S 259	APR212/4.5 ED 259	APR212/4.5LN ED 259
AP212/6.5 D 259	AP212/6.5LN D 259	AP212/6.5 S 259	AP212/6.5LN S 259	APR212/6.5 ED 259	APR212/6.5LN ED 259
AP212/8.5 D 259	AP212/8.5LN D 259	AP212/8.5 S 259	AP212/8.5LN S 259	APR212/8.5 ED 259	APR212/8.5LN ED 259
AP212/11 D 259	AP212/11LN D 259	AP212/11 S 259	AP212/11LN S 259	APR212/11 ED 259	APR212/11LN ED 259
AP212/15 D 259	AP212/15LN D 259	AP212/15 S 259	AP212/15LN S 259	APR212/15 ED 259	APR212/15LN ED 259
AP212/19 D 259	AP212/19LN D 259	AP212/19 S 259	AP212/19LN S 259	APR212/19 ED 259	APR212/19LN ED 259
AP212/22 D 259	AP212/22LN D 259	AP212/22 S 259	AP212/22LN S 259	APR212/22 ED 259	APR212/22LN ED 259
AP212/26 D 259	AP212/26LN D 259	AP212/26 S 259	AP212/26LN S 259	APR212/26 ED 259	APR212/26LN ED 259

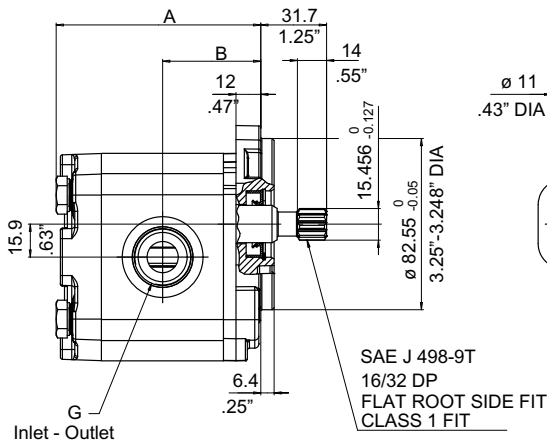
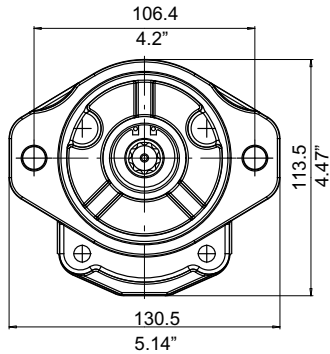
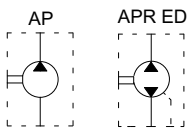

Serie
887S

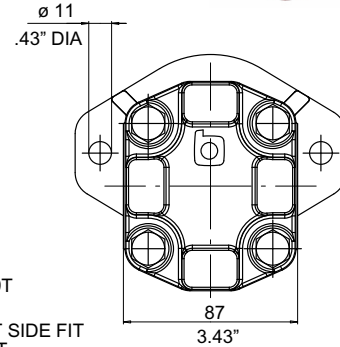
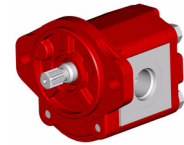

Gear pump material	
Front cover:	aluminium
Body:	aluminium
Back cover:	cast iron
Seals:	NBR + HNBR

Tightening torque: see section 3.5 - 3.6
Shaft max torque: see section 3.3

Reversible pump
ED - External Drain

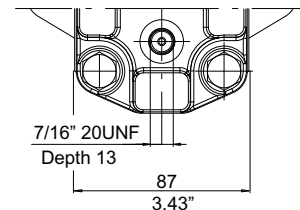

Type	Displacement cm ³ /rev		Dimensions				Suction G UNF	Pressure G UNF
	AP212	AP212LN	A		B			
			mm	inch	mm	inch		
4.5	4.4	4.5	88.5	3.48	42.5	1.67	1-1/16" 12 (SAE12)	7/8" 14 (SAE10)
6.5	6.4	6.6	91.5	3.60	44	1.73		
8.5	8.4	8.7	94.5	3.72	45.5	1.79		
11	11.1	11.5	98.5	3.88	47.5	1.87		
15	15.1	15.7	104.5	4.11	50.5	1.99		
19	19.2	19.8	110.5	4.35	53.5	2.11		
22	22.2	23	115	4.52	55.5	2.18		
26	26.2	27.1	121	4.76	58.5	2.30		

Clockwise rotation: D		Counter-clockwise rotation: S		Reversible pump External Drain	
Standard	Low Noise	Standard	Low Noise	Standard	Low Noise
AP212/4.5 D 887S	AP212/4.5LN D 887S	AP212/4.5 S 887S	AP212/4.5LN S 887S	APR212/4.5 ED 887S	APR212/4.5LN ED 887S
AP212/6.5 D 887S	AP212/6.5LN D 887S	AP212/6.5 S 887S	AP212/6.5LN S 887S	APR212/6.5 ED 887S	APR212/6.5LN ED 887S
AP212/8.5 D 887S	AP212/8.5LN D 887S	AP212/8.5 S 887S	AP212/8.5LN S 887S	APR212/8.5 ED 887S	APR212/8.5LN ED 887S
AP212/11 D 887S	AP212/11LN D 887S	AP212/11 S 887S	AP212/11LN S 887S	APR212/11 ED 887S	APR212/11LN ED 887S
AP212/15 D 887S	AP212/15LN D 887S	AP212/15 S 887S	AP212/15LN S 887S	APR212/15 ED 887S	APR212/15LN ED 887S
AP212/19 D 887S	AP212/19LN D 887S	AP212/19 S 887S	AP212/19LN S 887S	APR212/19 ED 887S	APR212/19LN ED 887S
AP212/22 D 887S	AP212/22LN D 887S	AP212/22 S 887S	AP212/22LN S 887S	APR212/22 ED 887S	APR212/22LN ED 887S
AP212/26 D 887S	AP212/26LN D 887S	AP212/26 S 887S	AP212/26LN S 887S	APR212/26 ED 887S	APR212/26LN ED 887S

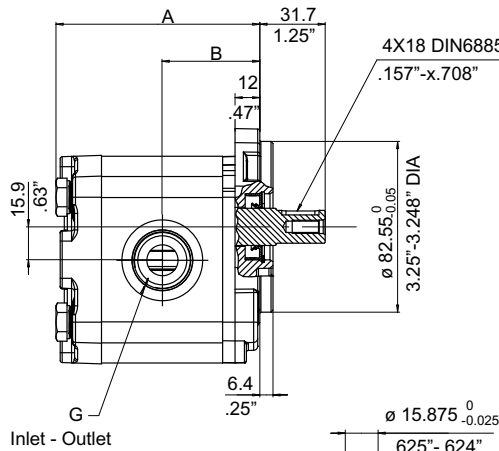
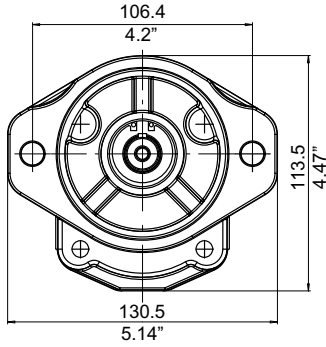
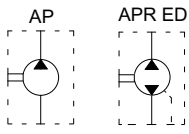

Serie
880

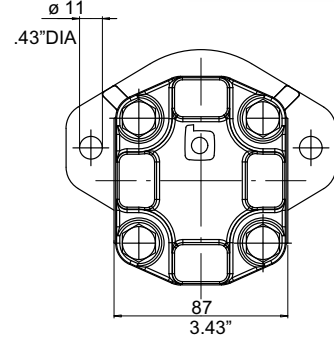
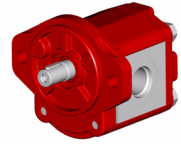

Gear pump material

Front cover: aluminium
Body: aluminium
Back cover: cast iron
Seals: NBR + HNBR

Tightening torque: see section 3.5 - 3.6
Shaft max torque: see section 3.3

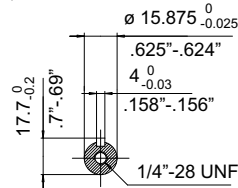

Reversible pump
ED - External Drain

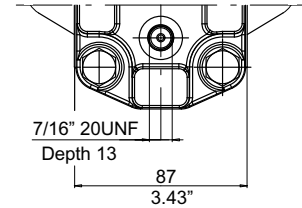

Type	Displacement cm ³ /rev		Dimensions				Suction G UNF	Pressure G UNF
	AP212	AP212LN	A		B			
			mm	inch	mm	inch		
4.5	4.4	4.5	88.5	3.48	42.5	1.67	1-1/16" 12 (SAE12)	7/8" 14 (SAE10)
6.5	6.4	6.6	91.5	3.60	44	1.73		
8.5	8.4	8.7	94.5	3.72	45.5	1.79		
11	11.1	11.5	98.5	3.88	47.5	1.87		
15	15.1	15.7	104.5	4.11	50.5	1.99		
19	19.2	19.8	110.5	4.35	53.5	2.11		
22	22.2	23	115	4.52	55.5	2.18		
26	26.2	27.1	121	4.76	58.5	2.30		

Clockwise rotation: D		Counter-clockwise rotation: S		Reversible pump External Drain	
Standard	Low Noise	Standard	Low Noise	Standard	Low Noise
AP212/4.5 D 880	AP212/4.5LN D 880	AP212/4.5 S 880	AP212/4.5LN S 880	APR212/4.5 ED 880	APR212/4.5LN ED 880
AP212/6.5 D 880	AP212/6.5LN D 880	AP212/6.5 S 880	AP212/6.5LN S 880	APR212/6.5 ED 880	APR212/6.5LN ED 880
AP212/8.5 D 880	AP212/8.5LN D 880	AP212/8.5 S 880	AP212/8.5LN S 880	APR212/8.5 ED 880	APR212/8.5LN ED 880
AP212/11 D 880	AP212/11LN D 880	AP212/11 S 880	AP212/11LN S 880	APR212/11 ED 880	APR212/11LN ED 880
AP212/15 D 880	AP212/15LN D 880	AP212/15 S 880	AP212/15LN S 880	APR212/15 ED 880	APR212/15LN ED 880
AP212/19 D 880	AP212/19LN D 880	AP212/19 S 880	AP212/19LN S 880	APR212/19 ED 880	APR212/19LN ED 880
AP212/22 D 880	AP212/22LN D 880	AP212/22 S 880	AP212/22LN S 880	APR212/22 ED 880	APR212/22LN ED 880
AP212/26 D 880	AP212/26LN D 880	AP212/26 S 880	AP212/26LN S 880	APR212/26 ED 880	APR212/26LN ED 880

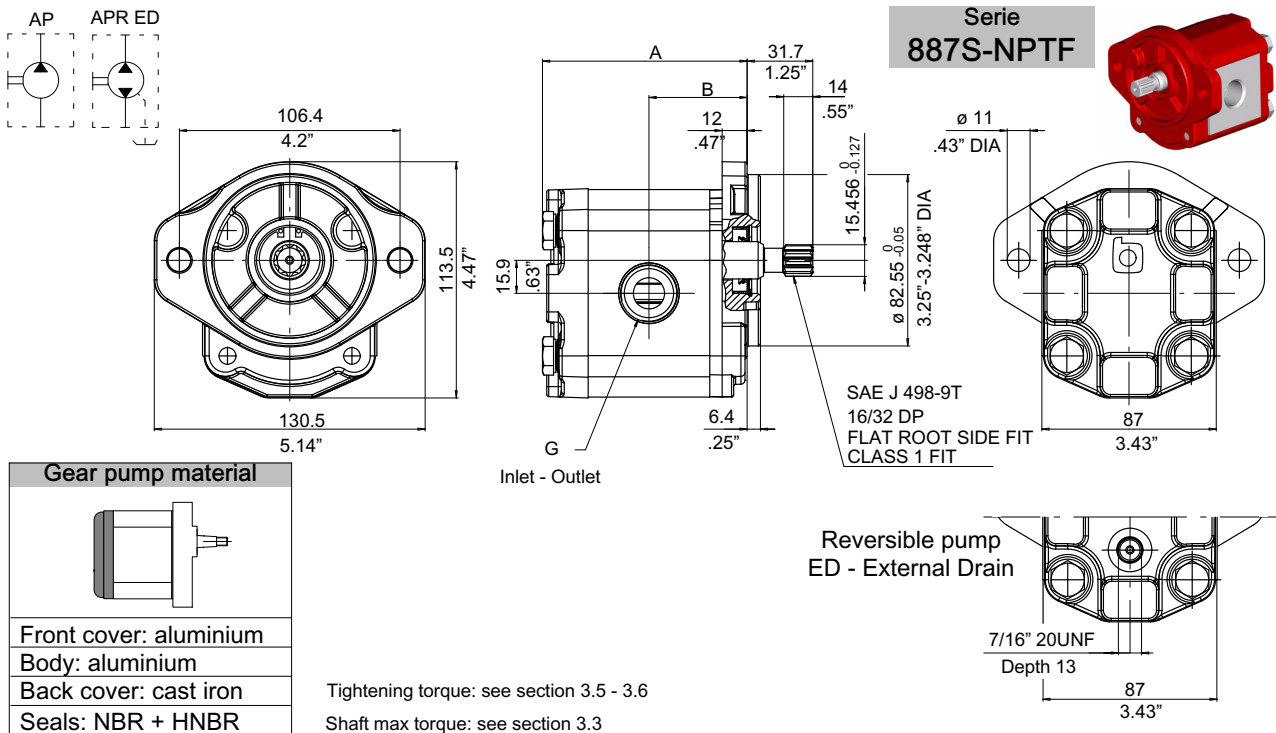

Type	Displacement cm ³ /rev		Dimensions				Suction G NPTF	Pressure G NPTF
	AP212	AP212LN	A		B			
			mm	inch	mm	inch		
4.5	4.4	4.5	88.5	3.48	42.5	1.67	1/2"	1/2"
6.5	6.4	6.6	91.5	3.60	44	1.73		
8.5	8.4	8.7	94.5	3.72	45.5	1.79		
11	11.1	11.5	98.5	3.88	47.5	1.87	3/4"	1/2"
15	15.1	15.7	104.5	4.11	50.5	1.99		
19	19.2	19.8	110.5	4.35	53.5	2.11		
22	22.2	23	115	4.52	55.5	2.18		
26	26.2	27.1	121	4.76	58.5	2.30		

Clockwise rotation: D		Counter-clockwise rotation: S		Reversible pump External Drain	
Standard	Low Noise	Standard	Low Noise	Standard	Low Noise
AP212/4.5 D 887S-NPTF	AP212/4.5LN D 887S-NPTF	AP212/4.5 S 887S-NPTF	AP212/4.5LN S 887S-NPTF	APR212/4.5 ED 887S-NPTF	APR212/4.5LN ED 887S-NPTF
AP212/6.5 D 887S-NPTF	AP212/6.5LN D 887S-NPTF	AP212/6.5 S 887S-NPTF	AP212/6.5LN S 887S-NPTF	APR212/6.5 ED 887S-NPTF	APR212/6.5LN ED 887S-NPTF
AP212/8.5 D 887S-NPTF	AP212/8.5LN D 887S-NPTF	AP212/8.5 S 887S-NPTF	AP212/8.5LN S 887S-NPTF	APR212/8.5 ED 887S-NPTF	APR212/8.5LN ED 887S-NPTF
AP212/11 D 887S-NPTF	AP212/11LN D 887S-NPTF	AP212/11 S 887S-NPTF	AP212/11LN S 887S-NPTF	APR212/11 ED 887S-NPTF	APR212/11LN ED 887S-NPTF
AP212/15 D 887S-NPTF	AP212/15LN D 887S-NPTF	AP212/15 S 887S-NPTF	AP212/15LN S 887S-NPTF	APR212/15 ED 887S-NPTF	APR212/15LN ED 887S-NPTF
AP212/19 D 887S-NPTF	AP212/19LN D 887S-NPTF	AP212/19 S 887S-NPTF	AP212/19LN S 887S-NPTF	APR212/19 ED 887S-NPTF	APR212/19LN ED 887S-NPTF
AP212/22 D 887S-NPTF	AP212/22LN D 887S-NPTF	AP212/22 S 887S-NPTF	AP212/22LN S 887S-NPTF	APR212/22 ED 887S-NPTF	APR212/22LN ED 887S-NPTF
AP212/26 D 887S-NPTF	AP212/26LN D 887S-NPTF	AP212/26 S 887S-NPTF	AP212/26LN S 887S-NPTF	APR212/26 ED 887S-NPTF	APR212/26LN ED 887S-NPTF

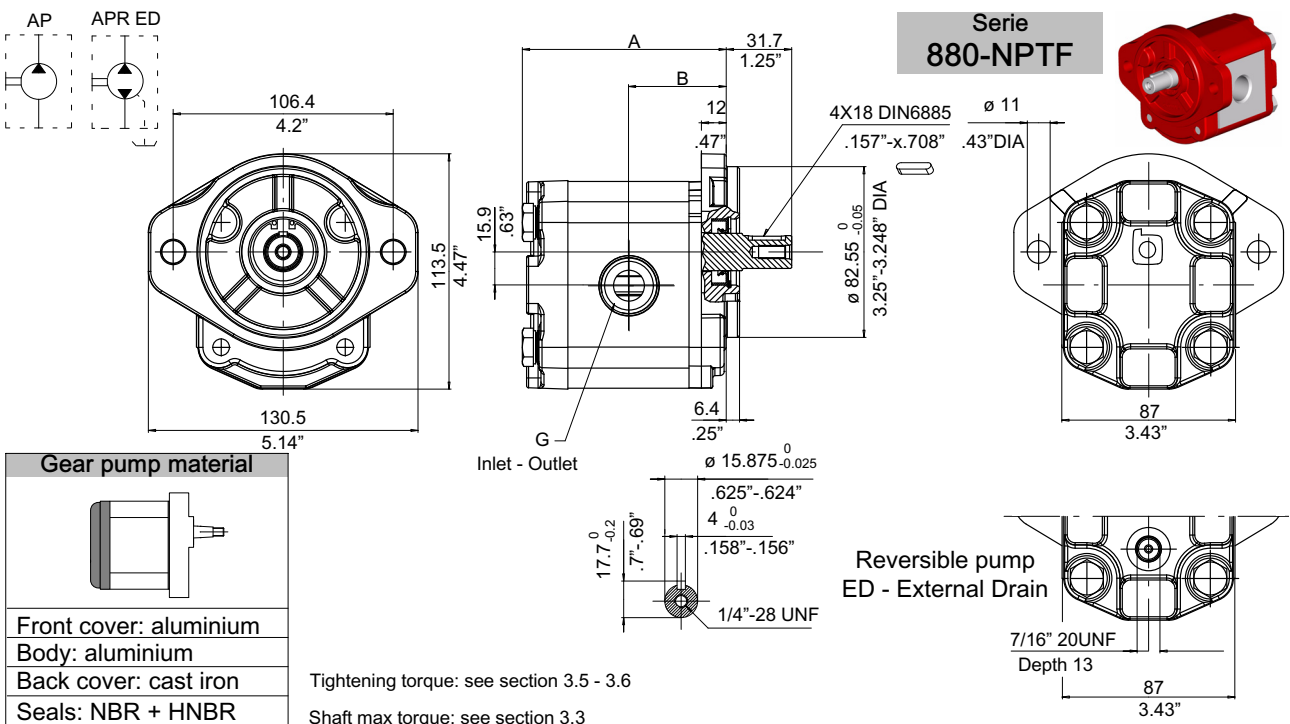

Type	Displacement cm ³ /rev		Dimensions				Suction G NPTF	Pressure G NPTF
	AP212	AP212LN	A		B			
			mm	inch	mm	inch		
4.5	4.4	4.5	88.5	3.48	42.5	1.67	1/2"	1/2"
6.5	6.4	6.6	91.5	3.60	44	1.73		
8.5	8.4	8.7	94.5	3.72	45.5	1.79		
11	11.1	11.5	98.5	3.88	47.5	1.87	3/4"	1/2"
15	15.1	15.7	104.5	4.11	50.5	1.99		
19	19.2	19.8	110.5	4.35	53.5	2.11		
22	22.2	23	115	4.52	55.5	2.18		
26	26.2	27.1	121	4.76	58.5	2.30		

Clockwise rotation: D		Counter-clockwise rotation: S		Reversible pump External Drain	
Standard	Low Noise	Standard	Low Noise	Standard	Low Noise
AP212/4.5 D 880-NPTF	AP212/4.5LN D 880-NPTF	AP212/4.5 S 880-NPTF	AP212/4.5LN S 880-NPTF	APR212/4.5 ED 880-NPTF	APR212/4.5LN ED 880-NPTF
AP212/6.5 D 880-NPTF	AP212/6.5LN D 880-NPTF	AP212/6.5 S 880-NPTF	AP212/6.5LN S 880-NPTF	APR212/6.5 ED 880-NPTF	APR212/6.5LN ED 880-NPTF
AP212/8.5 D 880-NPTF	AP212/8.5LN D 880-NPTF	AP212/8.5 S 880-NPTF	AP212/8.5LN S 880-NPTF	APR212/8.5 ED 880-NPTF	APR212/8.5LN ED 880-NPTF
AP212/11 D 880-NPTF	AP212/11LN D 880-NPTF	AP212/11 S 880-NPTF	AP212/11LN S 880-NPTF	APR212/11 ED 880-NPTF	APR212/11LN ED 880-NPTF
AP212/15 D 880-NPTF	AP212/15LN D 880-NPTF	AP212/15 S 880-NPTF	AP212/15LN S 880-NPTF	APR212/15 ED 880-NPTF	APR212/15LN ED 880-NPTF
AP212/19 D 880-NPTF	AP212/19LN D 880-NPTF	AP212/19 S 880-NPTF	AP212/19LN S 880-NPTF	APR212/19 ED 880-NPTF	APR212/19LN ED 880-NPTF
AP212/22 D 880-NPTF	AP212/22LN D 880-NPTF	AP212/22 S 880-NPTF	AP212/22LN S 880-NPTF	APR212/22 ED 880-NPTF	APR212/22LN ED 880-NPTF
AP212/26 D 880-NPTF	AP212/26LN D 880-NPTF	AP212/26 S 880-NPTF	AP212/26LN S 880-NPTF	APR212/26 ED 880-NPTF	APR212/26LN ED 880-NPTF

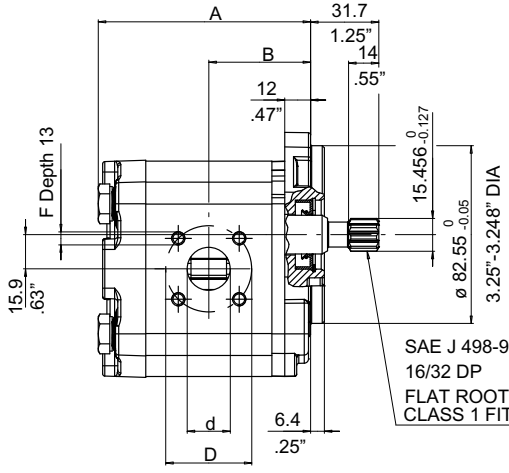
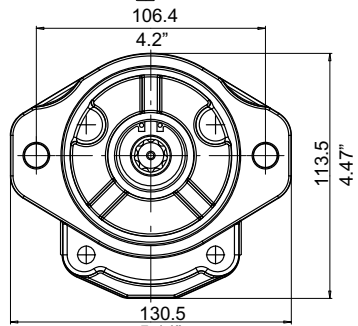
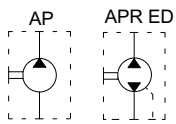

Serie
287S-B

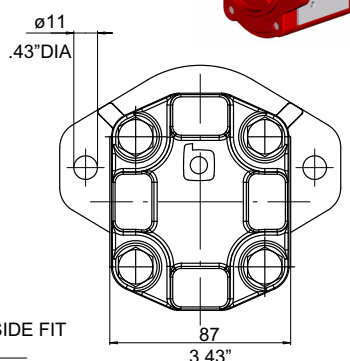
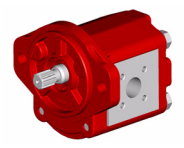

Gear pump material

Front cover: aluminium
Body: aluminium
Back cover: cast iron
Seals: NBR + HNBR

Reversible pump
ED - External Drain

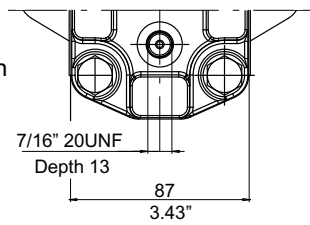

Tightening torque: see section 3.6
Shaft max torque: see section 3.3

Type	Displacement cm ³ /rev		Dimensions				Suction			Pressure						
	AP212	AP212LN	A mm	A inch	B mm	B inch	d mm	d inch	D mm	D inch	F mm	d mm	d inch	D mm	D inch	F mm
4.5	4.4	4.5	88.5	3.48	42.5	1.67	15	.59	40	1.58	M6X1	15	.59	35	1.38	M6X1
6.5	6.4	6.6	91.5	3.60	44	1.73										
8.5	8.4	8.7	94.5	3.72	45.5	1.79										
11	11.1	11.5	98.5	3.88	47.5	1.87	20	.79	40	1.58	M6X1	15	.59	35	1.38	M6X1
15	15.1	15.7	104.5	4.11	50.5	1.99										
19	19.2	19.8	110.5	4.35	53.5	2.11										
22	22.2	23	115	4.52	55.5	2.18										
26	26.2	27.1	121	4.76	58.5	2.30										

Clockwise rotation: D		Counter-clockwise rotation: S		Reversible pump External Drain	
Standard	Low Noise	Standard	Low Noise	Standard	Low Noise
AP212/4.5 D 287S-B	AP212/4.5LN D 287S-B	AP212/4.5 S 287S-B	AP212/4.5LN S 287S-B	APR212/4.5 ED 287S-B	APR212/4.5LN ED 287S-B
AP212/6.5 D 287S-B	AP212/6.5LN D 287S-B	AP212/6.5 S 287S-B	AP212/6.5LN S 287S-B	APR212/6.5 ED 287S-B	APR212/6.5LN ED 287S-B
AP212/8.5 D 287S-B	AP212/8.5LN D 287S-B	AP212/8.5 S 287S-B	AP212/8.5LN S 287S-B	APR212/8.5 ED 287S-B	APR212/8.5LN ED 287S-B
AP212/11 D 287S-B	AP212/11LN D 287S-B	AP212/11 S 287S-B	AP212/11LN S 287S-B	APR212/11 ED 287S-B	APR212/11LN ED 287S-B
AP212/15 D 287S-B	AP212/15LN D 287S-B	AP212/15 S 287S-B	AP212/15LN S 287S-B	APR212/15 ED 287S-B	APR212/15LN ED 287S-B
AP212/19 D 287S-B	AP212/19LN D 287S-B	AP212/19 S 287S-B	AP212/19LN S 287S-B	APR212/19 ED 287S-B	APR212/19LN ED 287S-B
AP212/22 D 287S-B	AP212/22LN D 287S-B	AP212/22 S 287S-B	AP212/22LN S 287S-B	APR212/22 ED 287S-B	APR212/22LN ED 287S-B
AP212/26 D 287S-B	AP212/26LN D 287S-B	AP212/26 S 287S-B	AP212/26LN S 287S-B	APR212/26 ED 287S-B	APR212/26LN ED 287S-B

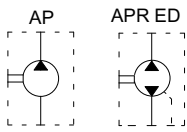

**Serie
280-B**

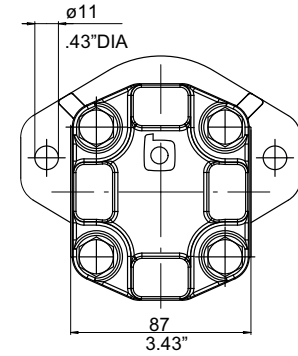
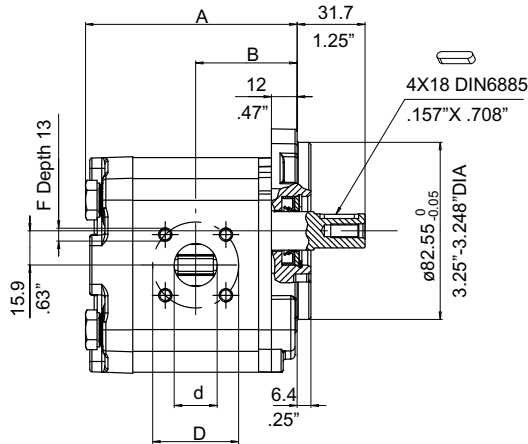
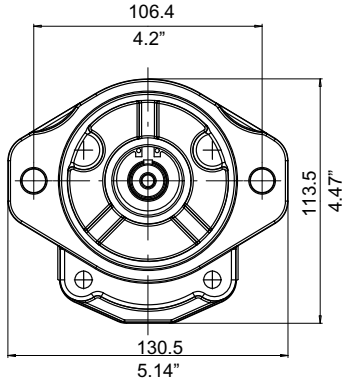
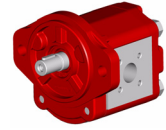

Gear pump material

Front cover: aluminium
Body: aluminium
Back cover: cast iron
Seals: NBR + HNBR

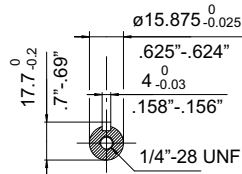

Tightening torque: see section 3.6
Shaft max torque: see section 3.3

**Reversible pump
ED - External Drain**

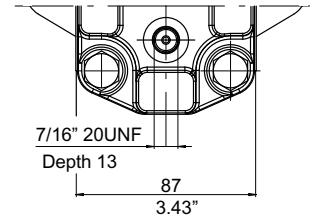

Type	Displacement cm ³ /rev		Dimensions				Suction			Pressure						
	AP212	AP212LN	A mm	inch	B mm	inch	d mm	inch	D mm	inch	F mm	d mm	inch	D mm	inch	F mm
4.5	4.4	4.5	88.5	3.48	42.5	1.67	15	.59	40	1.58	M6X1	15	.59	35	1.38	M6X1
6.5	6.4	6.6	91.5	3.60	44	1.73										
8.5	8.4	8.7	94.5	3.72	45.5	1.79										
11	11.1	11.5	98.5	3.88	47.5	1.87	20	.79	40	1.58	M6X1	15	.59	35	1.38	M6X1
15	15.1	15.7	104.5	4.11	50.5	1.99										
19	19.2	19.8	110.5	4.35	53.5	2.11										
22	22.2	23	115	4.52	55.5	2.18										
26	26.2	27.1	121	4.76	58.5	2.30										

Clockwise rotation: D		Counter-clockwise rotation: S		Reversible pump External Drain	
Standard	Low Noise	Standard	Low Noise	Standard	Low Noise
AP212/4.5 D 280-B	AP212/4.5LN D 280-B	AP212/4.5 S 280-B	AP212/4.5LN S 280-B	APR212/4.5 ED 280-B	APR212/4.5LN ED 280-B
AP212/6.5 D 280-B	AP212/6.5LN D 280-B	AP212/6.5 S 280-B	AP212/6.5LN S 280-B	APR212/6.5 ED 280-B	APR212/6.5LN ED 280-B
AP212/8.5 D 280-B	AP212/8.5LN D 280-B	AP212/8.5 S 280-B	AP212/8.5LN S 280-B	APR212/8.5 ED 280-B	APR212/8.5LN ED 280-B
AP212/11 D 280-B	AP212/11LN D 280-B	AP212/11 S 280-B	AP212/11LN S 280-B	APR212/11 ED 280-B	APR212/11LN ED 280-B
AP212/15 D 280-B	AP212/15LN D 280-B	AP212/15 S 280-B	AP212/15LN S 280-B	APR212/15 ED 280-B	APR212/15LN ED 280-B
AP212/19 D 280-B	AP212/19LN D 280-B	AP212/19 S 280-B	AP212/19LN S 280-B	APR212/19 ED 280-B	APR212/19LN ED 280-B
AP212/22 D 280-B	AP212/22LN D 280-B	AP212/22 S 280-B	AP212/22LN S 280-B	APR212/22 ED 280-B	APR212/22LN ED 280-B
AP212/26 D 280-B	AP212/26LN D 280-B	AP212/26 S 280-B	AP212/26LN S 280-B	APR212/26 ED 280-B	APR212/26LN ED 280-B

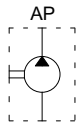

Serie
287S-SAEB

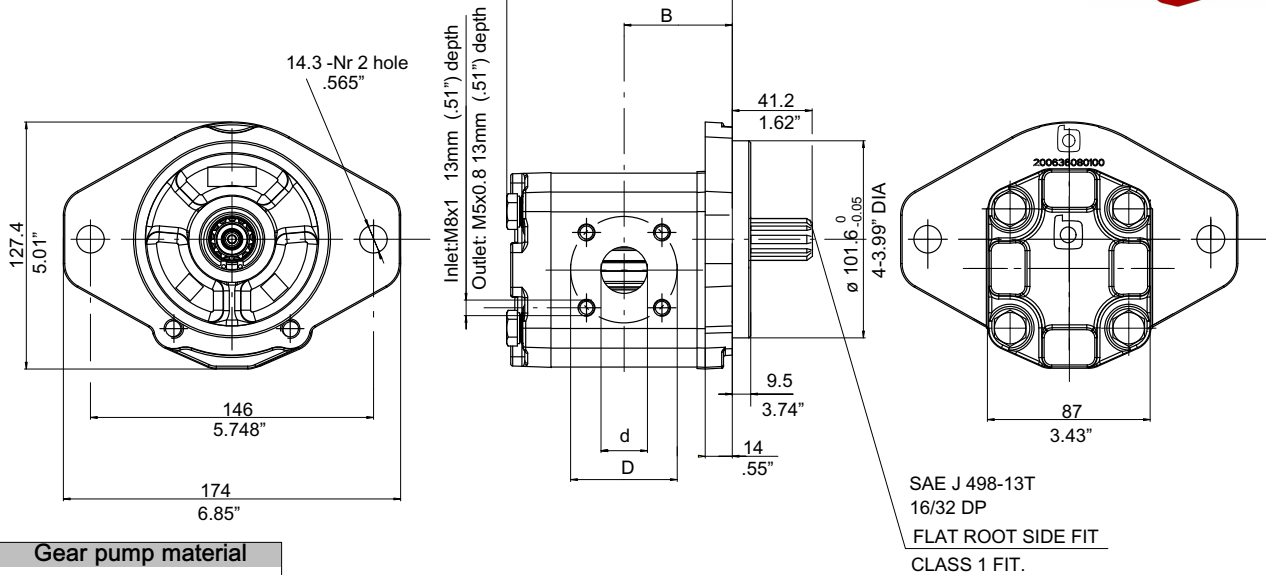
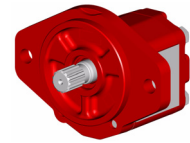

Gear pump material

Front cover: cast iron
Body: aluminium
Back cover: cast iron
Seals: NBR + HNBR

Shaft max torque: see section 3.3



Attention! It is not possible to change the rotation direction. Please order always with the right code

Type	Displacement cm ³ /rev		Dimensions				Suction				Pressure					
	AP212	AP212LN	A		B		d		D		F	d		D		F
			mm	inch	mm	inch	mm	inch	mm	inch	mm	mm	inch	mm	inch	mm
19	19.2	19.8	110.5	4.35	53.5	2.11	24	.95	55	2.17	M8x1	15	.59	35	1.38	M5x0.8
22	22.2	23	115	4.53	55.5	2.18										
26	26.2	27.1	121	4.76	58.5	2.30										

Clockwise rotation: D				Counter-clockwise rotation: S			
Standard		Low Noise		Standard		Low Noise	
AP212/19 D 287S-SAEB		AP212/19LN D 287S-SAEB		AP212/19 S 287S-SAEB		AP212/19LN S 287S-SAEB	
AP212/22 D 287S-SAEB		AP212/22LN D 287S-SAEB		AP212/22 S 287S-SAEB		AP212/22LN S 287S-SAEB	
AP212/26 D 287S-SAEB		AP212/26LN D 287S-SAEB		AP212/26 S 287S-SAEB		AP212/26LN S 287S-SAEB	

For availability of other displacements bodies please contact our Sales Center

3 AP212 Single pump customised versions

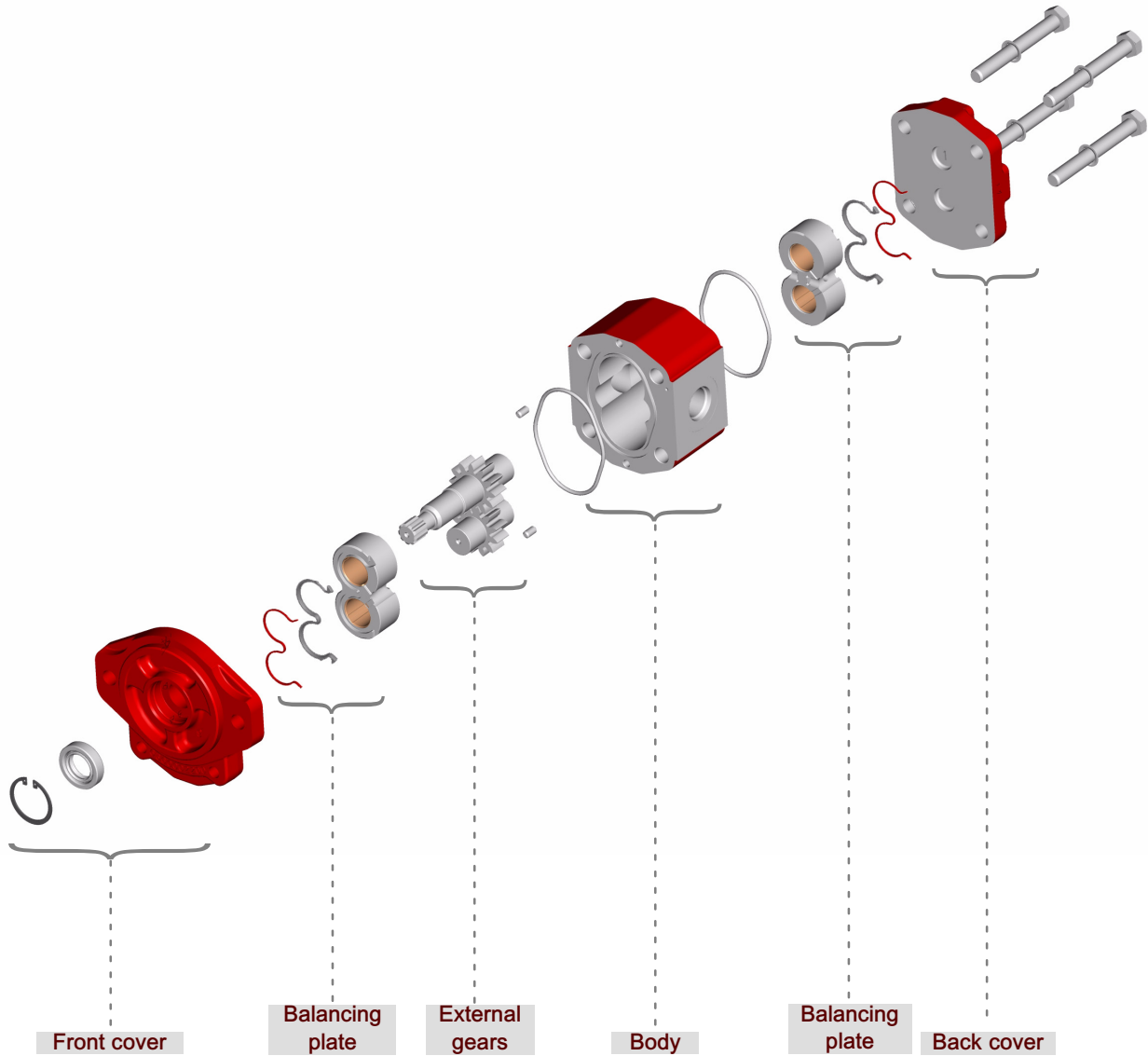



In this section, a single AP212 pump can be configured and customized.

AP212 wide availability of covers, bodies, gears and seals sets provides great flexibility to AP212 pump range and allows several different pump configurations.

In order to simplify the selection of the desired pump combination, a 'configurator form' is available and, by filling it out, it will guide you in the pump creation process.

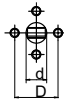
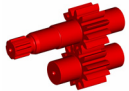
3.1 Single pump customised versions order example

A	P	R	2	1	2	/	4	.	5	L	N	-	-	A	0	S	-	1	C	N	-	G	H	1	-	A	*
<p>Function AP= single gear pump - unidirectional APR = single gear pump - reversible</p>		<p>Series 212</p>		<p>Displacement 4.5= 4.4 cm³/rev 6.5= 6.4 cm³/rev 8.5= 8.4 cm³/rev 11= 11.1 cm³/rev 15= 15.1 cm³/rev 19= 19.2 cm³/rev 22= 22.2 cm³/rev 26= 26.2 cm³/rev</p>		<p>Version Omitted if 12 teeth standard LN= 12 teeth Low Noise version</p>		<p>Rotation S = left-hand rotation D = Right-hand rotation Omitted if reversible version</p>		<p>Shaft end code see section 3.3</p>		<p>Shaft seal material type code see section 3.4.1</p>		<p>Front cover series/material with/without bearing code see section 3.4.2 and 3.4.3</p>		<p>Type of ports code see section 3.5</p> 		<p>Inlet/outlet port size code combination see section 3.5</p> 		<p>Body material + seal material code see section 3.5.1</p>		<p>Back cover type see section 3.6</p>		<p>BHRE section : Version - Progressive number (omitted)</p>			
																											

3.2 Single pump dimensions

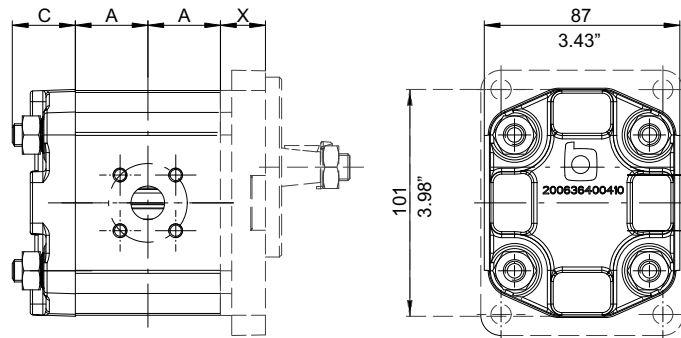

Pump size	A		C*	
	mm	inches	mm	inches
AP212/4.5	24.3	0.96	28	1.10
AP212/6.5	25.8	1.02		
AP212/8.5	27.3	1.08		
AP212/11	29.3	1.54		
AP212/15	32.3	1.27		
AP212/19	35.3	1.39		
AP212/22	37.6	1.48		
AP212/26	40.6	1.60		

C*: dimensions with standard back cover in cast iron .
For other back covers dimension see section 3.6

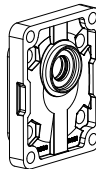
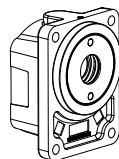
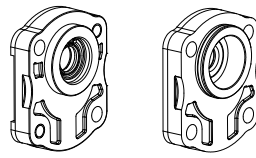
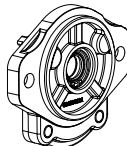
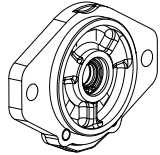

3.2.1 Front cover dimensions

Front cover type	x		Front cover type	x	
	mm	inches		mm	inches
German rectangular 	20	0.79	European rectangular 	19	0.75
Bearing support German version 	48.5	1.91	Through 2 bolts 	17.2	0.68
SAE-A 2 bolts 	18	0.71	SAE-B 2 bolts 	18.2	0.72

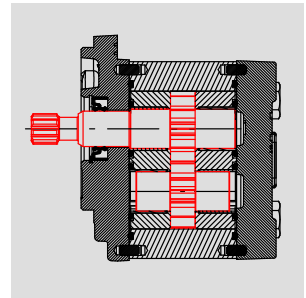
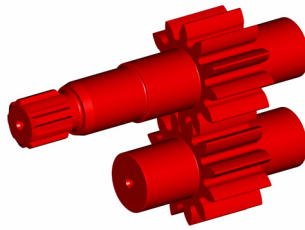
3.3 Shaft end code

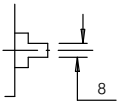
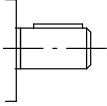
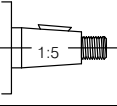
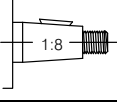
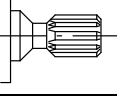
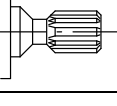
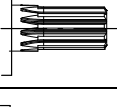
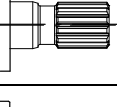

A P 2 1 2 / 8 . 5 - S - **A** 0 S - 1 C N - V E 1 6 - A

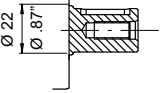
Shaft end shape	Shaft end ordering code	Max torque
	M	T max = 65 Nm
	S	T max = 65 Nm
	G	T max = 135 Nm
	E	T max = 135 Nm
	D	T max = 110 Nm
	A	T max = 90 Nm
	T	T max = 140 Nm
	B	T max = 270 Nm
	See section 3.4.3	T max = 100 Nm
	See section 3.4.3	T max = 100 Nm

3.4 Front cover

3.4.1 Shaft seal material

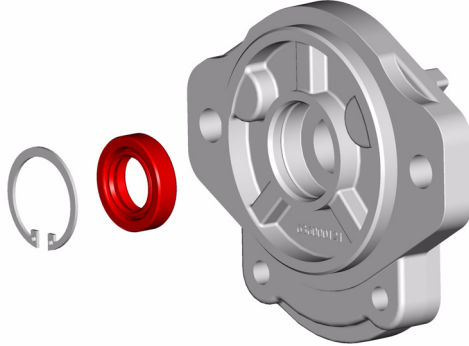

A P 2 1 2 / 8 . 5 - S - A 0 S - 1 C N - V E 1 6 - A



Shaft seal Type/material	Ordering code
Shaft seal pump NBR (standard)	0
Shaft seal pump HNBR	1
FPM (VITON)	2
Shaft seal front bearing application	see section 3.4.3

3.4.2 Front cover type

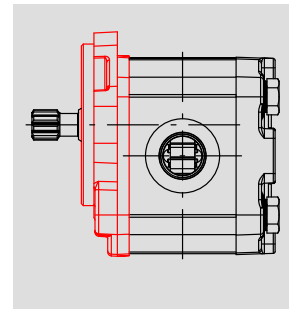
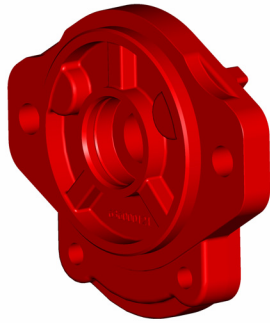

A P 2 1 2 / 8 . 5 - S - A 0 S - 1 C N - V E 1 6 - A

Type	Alluminium		Cast iron		Cast iron + bearing	
	Shape	Ordering code	Shape	Ordering code	Shape	Ordering code
German rectangular (Ø 80 mm - 3.15 inches)		A		B		see section 3.4.3
European rectangular (Ø 36.5 mm - 1.44")		D		E		*
Through 2 bolts (Ø 50 mm - 1.97")		G		H		*
Through 2 bolts (Ø 50 mm - 1.97")		L		M		*
Through 2 bolts (Ø 52 mm - 2.045")		O		P		
SAE-A 2 bolts (Ø 82.55 mm - 3.25 inches)		R		S		*
SAE-B 2 bolts (Ø 101,6 mm - 4 inches)				V		

Aluminium and cast iron front cover dimensions: see standard pumps data sheet

* Please contact our Sales Department

3.4.3 Front bearing application

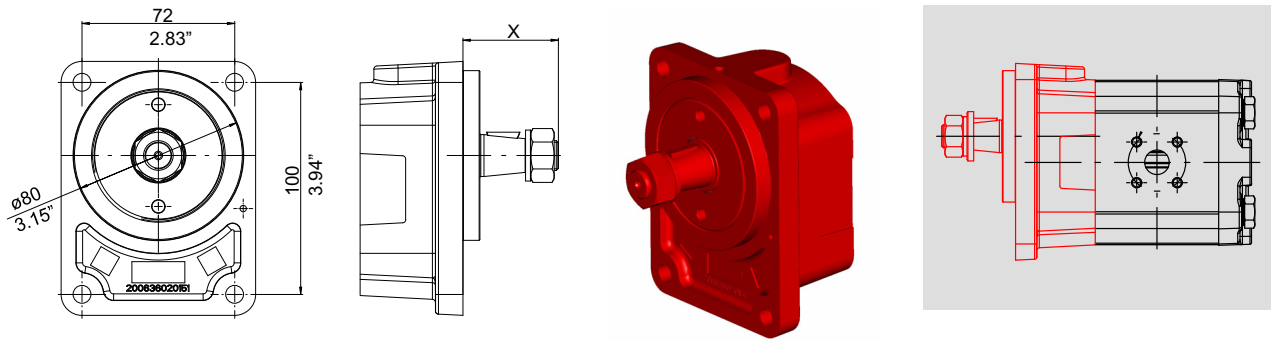

A P 2 1 2 / 8 . 5 - S - P 1 - 1 C N - V E 1 6 - A

	+	<p>T max = 100 Nm X = 45 mm (1.77 inches)</p>	+	Shaft seal material: HNBR	=	P1
	+	<p>Straight 22 mm - 0.87 inches X = 48.5 mm (1.91 inches)</p>	+	Shaft seal material: HNBR	=	C1

3.5 Body

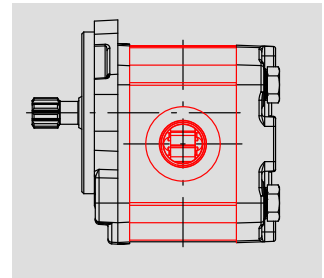
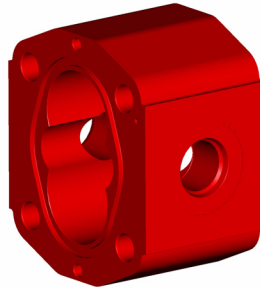

For reversible pumps alternative inlet and outlet ports have the same sizes as per inlet unidirectional rotation.

A	P	2	1	2	/	8	.	5	-	S	-	A	0	S	-	1	C	N	-	V	E	1	6	-	A
---	---	---	---	---	---	---	---	---	---	---	---	---	---	---	---	---	---	---	---	---	---	---	---	---	---

Port type	Ordering code	Displacement	Dimension (mm - inch)		Ordering code
			Suction	Pressure	
	without	0	All		0
			19**-22**-26**		D

Port type	Ordering code	Displacement	Dimension (mm - inch)		Ordering code
			Suction	Pressure	
	metric	1	4.5-6.5-8.5	On demand	A
			11-15		B
			19-22-26		C
			19**-22**-26**		D

Port type	Ordering code	Displacement	Dimension (mm - inch)		Ordering code	
			Suction	Pressure		
	BSPP threaded ports	4	4.5-6.5-8.5	3/8"	3/8"	A
			11-15	1/2"	3/8"	B
			19-22-26	3/4"	1/2"	C
			19**-22**-26**	3/4"	1/2"	D

At pressure P2 > 210 bar limited service life

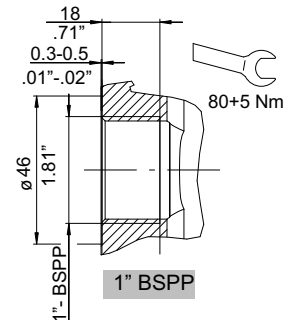
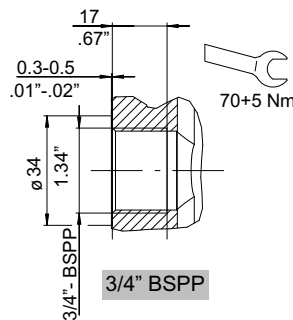
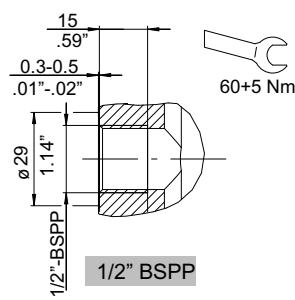
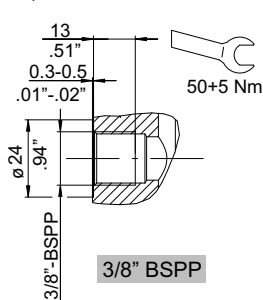

Port type	Ordering code	Displacement	Dimension (mm - inch)		Ordering code
			Suction	Pressure	
 SAE threaded ports	8	all	1-1/16" 12UNF (SAE12)	7/8" 14UNF (SAE10)	A
		4.5-6.5-8.5	3/4" 16UNF (SAE8)	3/4" 16UNF (SAE8)	B
		19** -22** -26**	1-1/16" 12UNF (SAE12)	7/8" 14UNF (SAE10)	D

At pressure P2 > 210 bar limited service life

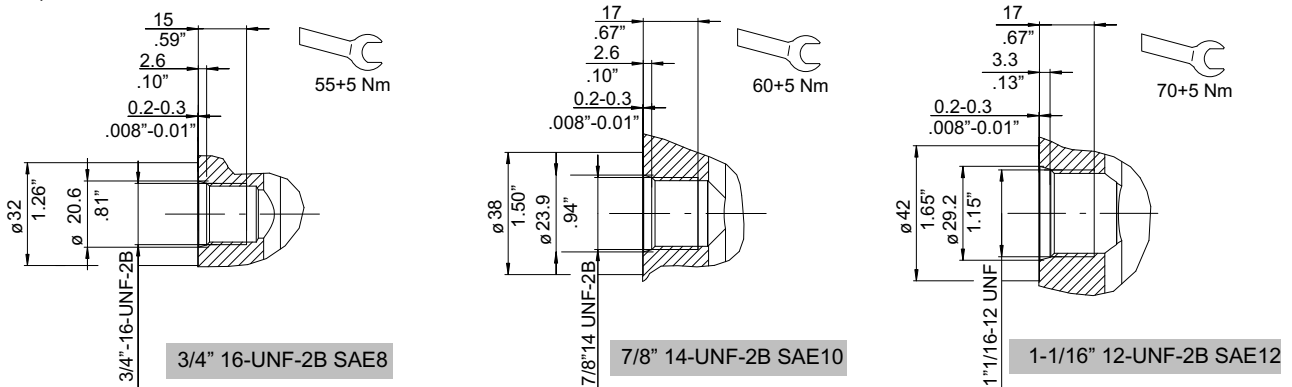

 NPTF threaded ports	6	4.5-6.5-8.5	1/2"	1/2"	A
		11-15-19-22-26	3/4"	1/2"	B
		19** -22** -26**	3/4"	1/2"	D

At pressure P2 > 210 bar limited service life

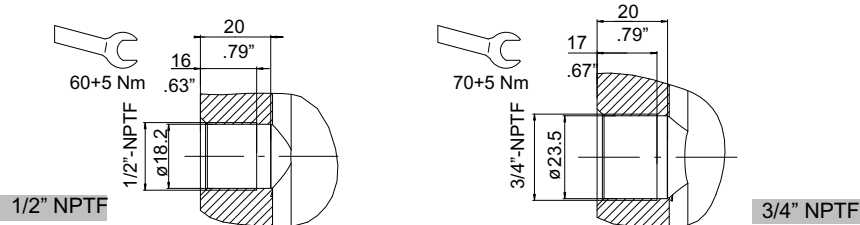

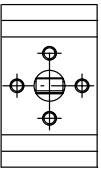
 European 4 bolt	3	4.5-6.5-8.5	13.5 - .53 (d) 30 - 1.18 (D) M6 (F)	13.5 - .53 (d) 30 - 1.18 (D) M6 (F)	A
		11-15	19 - .75 (d) 40 - 1.58 (D) M8 (F)	13.5 - .53 (d) 30 - 1.18 (D) M6 (F)	B
		19-22-26	19 - .75 (d) 40 - 1.58 (D) M8 (F)	19 - .75 (d) 40 - 1.58 (D) M8 (F)	C

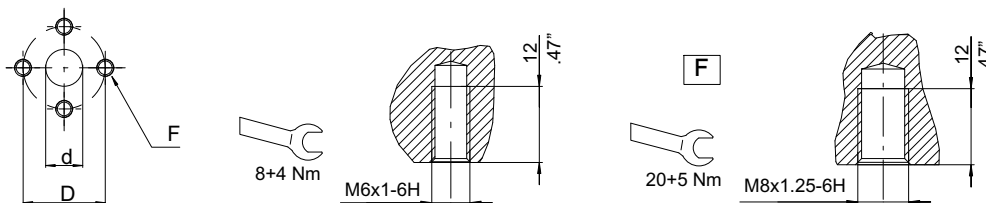

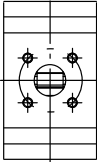
Type	Ordering code	Displacement	Dimension (mm - inch)		Ordering code
			Suction	Pressure	
 German 4 bolt flanged	2	4.5-6.5-8.5	15 - .59 (d) 40 - 1.58 (D) M6 (F)	15 - .59 (d) 35 - 1.38 (D) M6 (F) 287-S SAEB: M5 (F)	A
		11-15-19-22-26	20 - .79 (d) 40 - 1.58 (D) M6 (F)		B
		19-22-26 (287-S SAEB)	24 - .95 (d) 55 - 2.17 (D) M8 (F) (287-S SAEB)		C
		19**-22**-26**	20 - .79 (d) 40 - 1.58 (D) M6 (F)		D

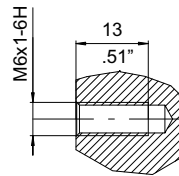
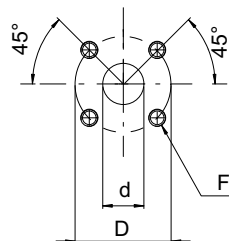

F

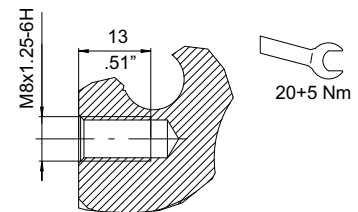

Other ports	9	If the requested port type is not included in the previous versions, please indicate number "9" and specify the details in the request note
-------------	---	---

3.5.1 Body and seal materials

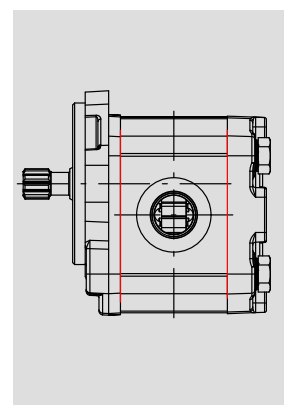
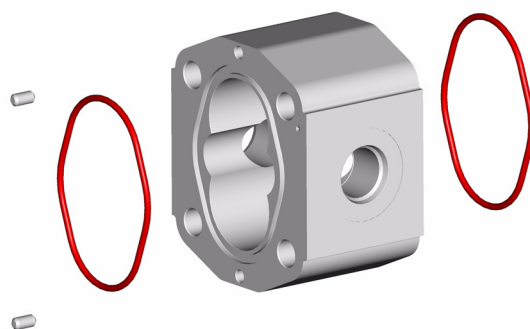

A	P	2	1	2	/	8	.	5	-	S	-	A	0	S	-	1	C	N	-	V	E	1	6	-	A
---	---	---	---	---	---	---	---	---	---	---	---	---	---	---	---	---	---	---	---	---	---	---	---	---	---



Body material	Seal material	Ordering code
Aluminium alloy	NBR (standard)	N
Aluminium alloy	HNBR	H

3.6 Back covers

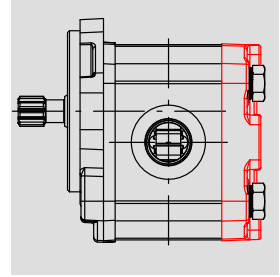
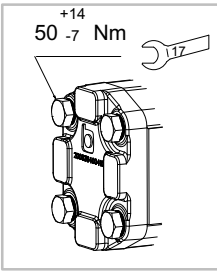

3.6.1 Cast iron back cover - Standard version for unidirectional pump

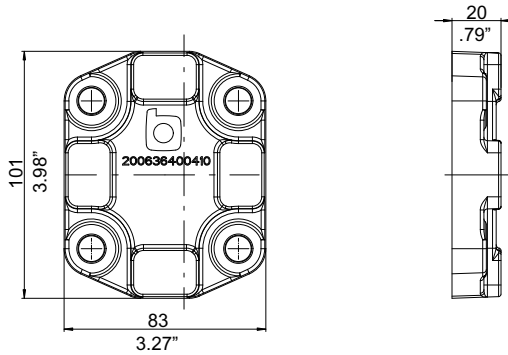

A	P	2	1	2	/	8	.	5	-	S	-	A	0	S	-	1	C	N	-	G	H	-	-	-	A
---	---	---	---	---	---	---	---	---	---	---	---	---	---	---	---	---	---	---	---	---	---	---	---	---	---

Type	Ordering code
Back cover, standard version, cast iron material	GH

3.6.2 Cast iron back cover with drain port - Standard version for bidirectional pump

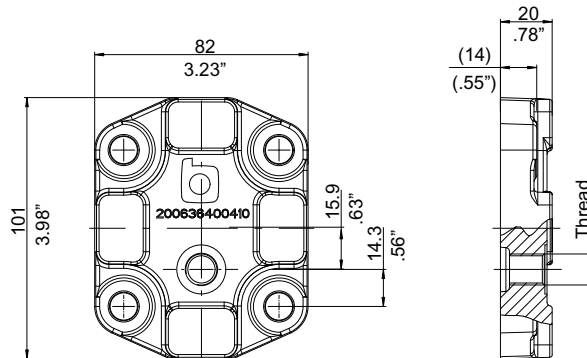

A	P	2	1	2	/	8	.	5	-	A	0	S	-	1	C	N	-	G	1	-	-	-	A
---	---	---	---	---	---	---	---	---	---	---	---	---	---	---	---	---	---	---	---	---	---	---	---

Type	Thread	Tightening torque	Ordering code
Back cover with external drain line, cast iron material for reversible pump	1/4" BSP	30 ⁻⁶ ₊₇ Nm	G1 (Standard)
	SAE4	20 ⁻⁵ ₊₅ Nm	G2
	M12x1.5	30 ⁻⁶ ₊₇ Nm	G3

3.6.3 Cast iron back cover with relief valve VI

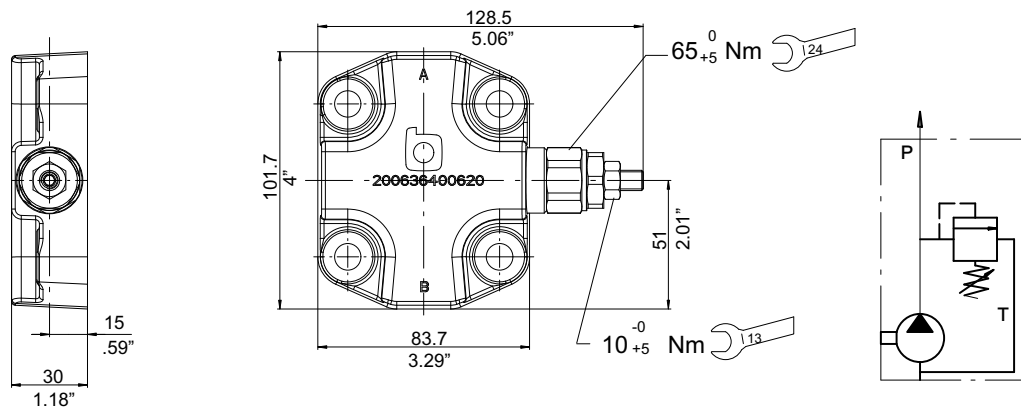

A	P	2	1	2	/	8	.	5	-	S	-	A	1	S	-	1	C	A	-	V	I	*	*	-	A
---	---	---	---	---	---	---	---	---	---	---	---	---	---	---	---	---	---	---	---	---	---	---	---	---	---

Type	Ordering code
Cast iron back cover with relief valve. Return to internal pump suction	VI**

** pressure set value (bar) - in example: VI15 = 150 bar



Attention: Please take care that when the relief valve open, oil temperature increase quickly. These conditions have effect in the pump performances and life

3.6.4 Cast iron back cover with relief valve VE

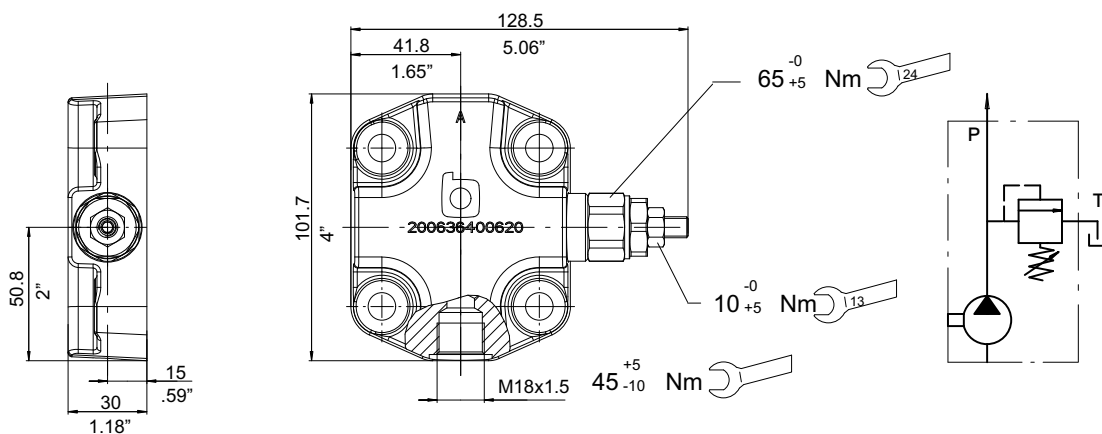

A	P	2	1	2	/	8	.	5	-	S	-	A	1	S	-	1	C	A	-	V	E	*	*	-	A
---	---	---	---	---	---	---	---	---	---	---	---	---	---	---	---	---	---	---	---	---	---	---	---	---	---

Type	Ordering code
Cast iron back cover with relief valve. Return to external pump tank	VE**

** pressure set value (bar) - in example: VE06 = 60 bar

3.6.5 Pressure relief valve : **VM01C
VI and VE** pressure setting range**

Direct acting
Balanced piston
Adjustable setting
Four setting ranges

Max. Pressure 350 bar ***
Max flow rate 60 l/min.
Temperature range -20/+100 °C
Weight: 0.155 Kg.

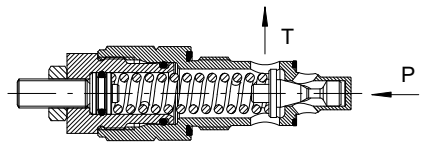
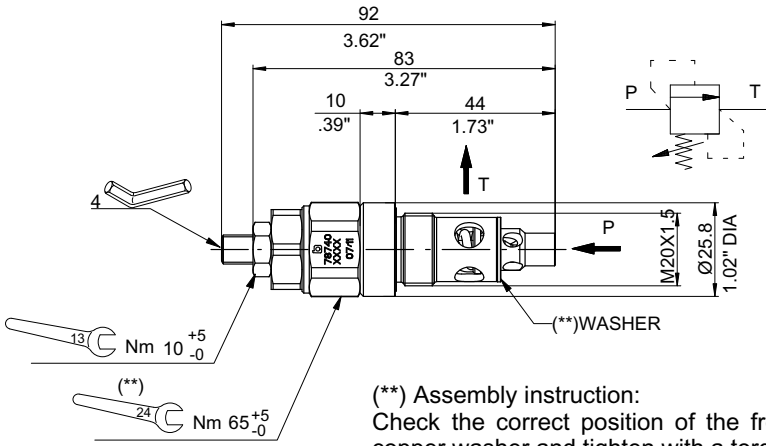

The valve can be sealed against tampering

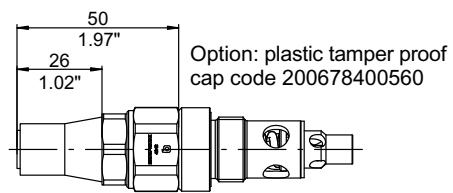

Pressure viscosity characteristic 46 cSt at 40°C

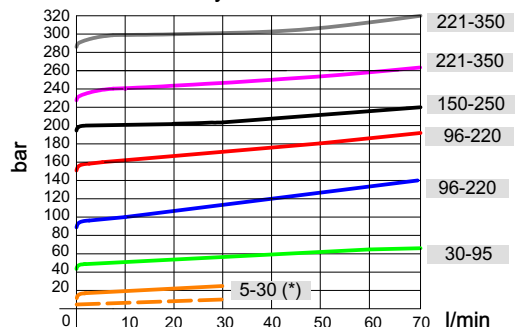

(*) see performances trace/minimum pressure setting (---)

The purpose of a relief valve is to keep the maximum system pressure at a safe level. When the external gear pump is supplied with pressure relief valves, the correct calibration is provided by Bucher Hydraulics S.p.A. and there are no reasons to change this value. When ordering, state in full the sheath part number, and, if the valve is to be supplied with sheath already fitted, the relief pressure setting required.

*** Maximum admitted pressure value: referred to valve only. For max admitted values see pump limits.

Performances	
Max. flow	60 l/min.
Pressure setting flow	5 l/min
Max internal leakage	200 cm ³ /min at 80% of nominal pressure setting
Oil viscosity	12 to 400 cSt
Oil temperature	-20 to 100 °C
Recommended filtration	21/19/16 (10 NAS 1638)
Marking info:	Printed code and date

Spring	Spring code	Setting range	Standard setting	Q max (l/min)	Type	Relief valve only code
00	-	Plugged	Without valve	-	00VC00	200978400140
02	200662403160	5 - 30 bar	20 bar	30 (*)	02VM01C	200787403600
05	200662403080	30 - 95 bar	50 bar	60	05VM01C	200787403480
12	200662403050	96 - 220 bar	120 bar	60	12VM01C	200787403420
15	200662403070	150 - 250 bar	150 bar	60	15VM01C	200787403470
23	200662403060	221 - 350 bar	230 bar	60	23VM01C	200787403430

Pressure setting valve referred to 5 l/min

3.6.6 Aluminium back cover with priority valve VP

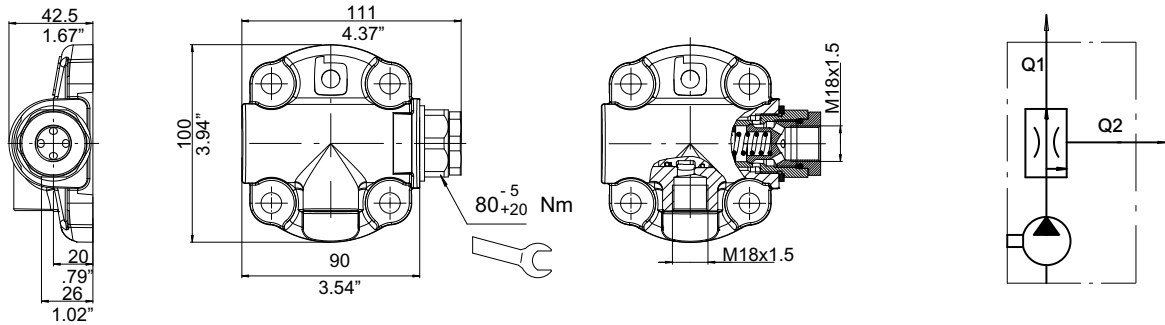

A P 2 1 2 / 8 . 5 - S - A 0 S - 1 C N - V P * * - A

** flow set value (l/min) - in example: VP02= 2.5 l/min

Type	Ordering code	Standard setting value +15% / -10% (l/min)									
		02	03	05	06	08	10	13	16	20	24
Aluminium back cover with with priority valve	VP**	2.5	3.5	5	6	8.5	10.5	13	16	20	24

3.6.7 Aluminium back cover with flow regulator valve QI

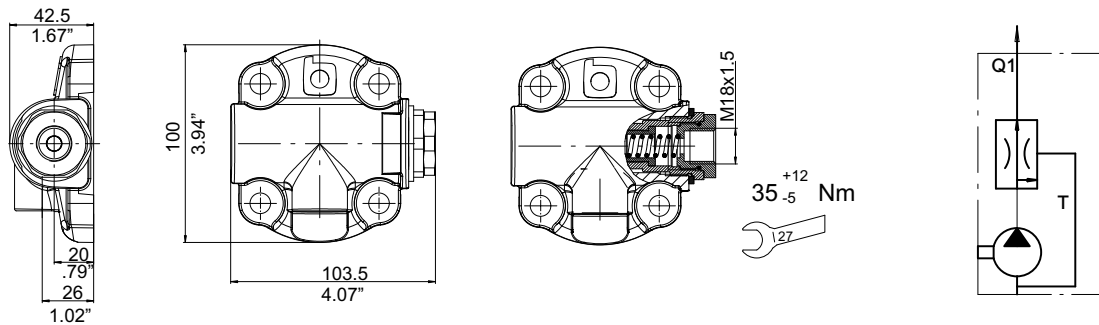

A P 2 1 2 / 8 . 5 - S - A 0 S - 1 C N - Q I * * - A

** flow set value (l/min) - in example: QI02= 2 l/min

Type	Ordering code	Standard setting value -10% (l/min)									
		02	03	05	06	08	09	12	16	19	23
Aluminium back cover with flow regulator valve, internal drain	QI**	2	3.5	5	6	7.5	9	12	16	19	23

3.6.8 Aluminium back cover with flow regulator valve QE

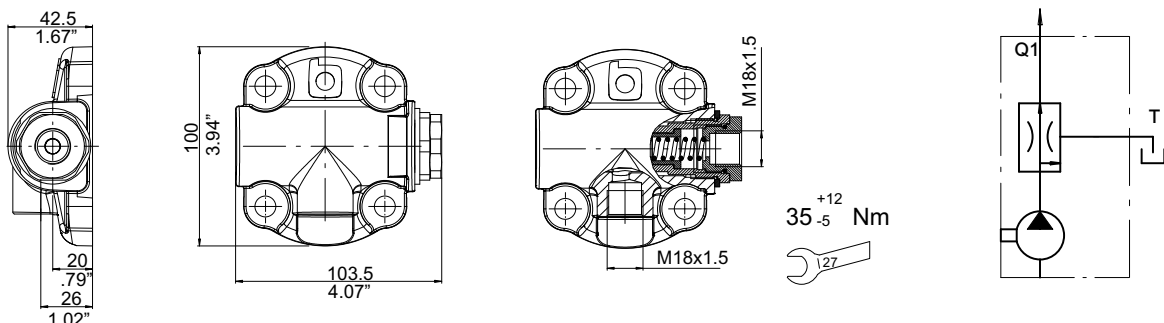

A P 2 1 2 / 8 . 5 - S - A 0 S - 1 C N - Q E * * - A

** flow set value (l/min) - in example: QE06= 6 l/min

Type	Ordering code	Standard setting value +15% (l/min)									
		02	03	05	06	08	09	12	16	19	23
Aluminium back cover with flow regulator valve, external drain	QE**	2	3.5	5	6	7.5	9	12	16	19	23

4 Multiple gear pumps

The multiple external gear pumps standard version includes an intermediate cover without shaft seal between the

pumps. If needed, it is possible to order a customised version with intermediate seal, see section 4.3.

4.1 Drive torque

$$T_{\max} = T_1 + T_2 \text{ <see section 3.3>}$$

Drive gear 1st pump

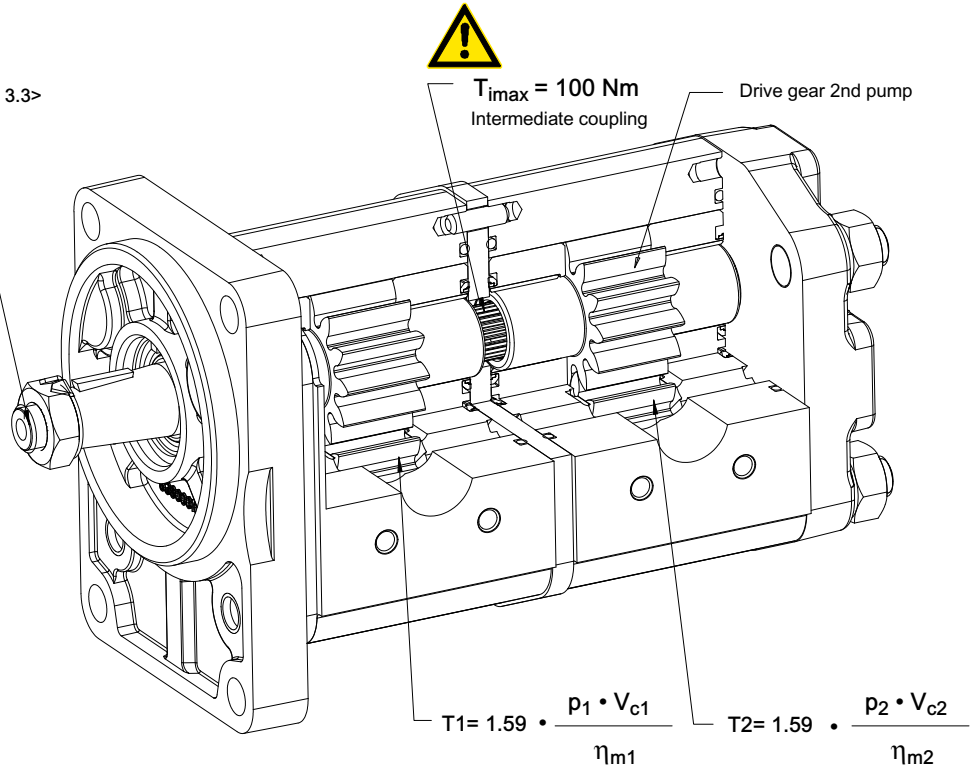

$$T_{\max} = 1.59 \cdot \frac{p_1 \cdot V_{c1}}{\eta_{m1}} + 1.59 \cdot \frac{p_2 \cdot V_{c2}}{\eta_{m2}}$$

Example: AP212/19 + AP212/15

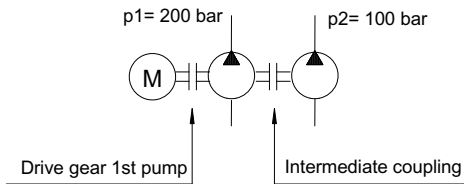

$$T_{\max} = 1.59 \cdot \frac{19.2 \cdot 200}{90} + 1.59 \cdot \frac{15.1 \cdot 100}{90} = 68 + 26.7 = 94.7 \text{ Nm}$$

$$T_{\max} = 94.7 \leq 130 \text{ Nm}$$

(taper 1:8)

$$T_2 = 26.7 \leq M_{i\max} 100 \text{ Nm}$$

4.2 Tandem pumps dimensions (standard version without shaft seal between the pumps)

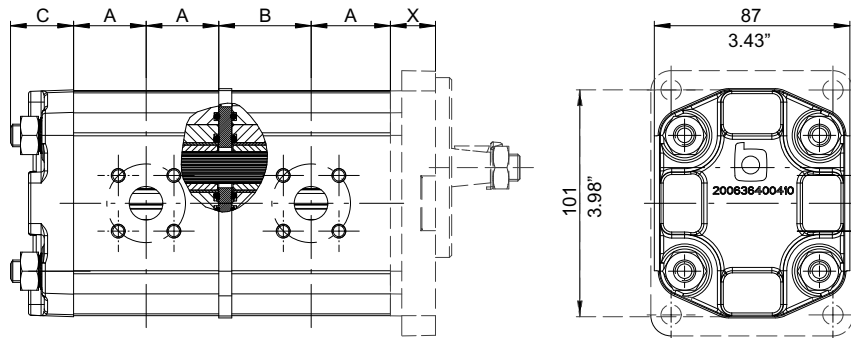

Pump size	A		B		C*	
	mm	inches	mm	inches	mm	inches
AP212/4.5	24.3	0.96	30.1	1.19	28	1.10
AP212/6.5	25.8	1.02	31.6	1.24		
AP212/8.5	27.3	1.08	33.1	1.30		
AP212/11	29.3	1.54	35.1	1.38		
AP212/15	32.3	1.27	38.1	1.50		
AP212/19	35.3	1.39	41.1	1.62		
AP212/22	37.6	1.48	43.4	1.71		
AP212/26	40.6	1.60	46.4	1.83		

C*: dimensions with standard back cover in cast iron .
For other back covers dimension see section 3.6

4.2.1 Standard versions, dimensions example

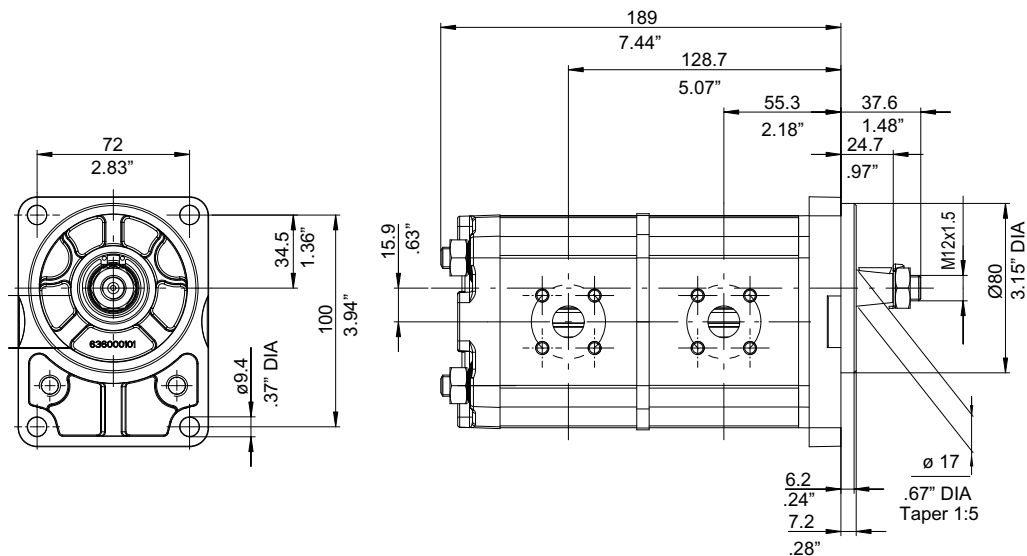

Example

Total length: $189 \text{ mm} = 20 + 35.3 + 41.1 + 32.3 + 32.3 + 28 (X + A + B + A + A + C)$

Port position: $128.7 \text{ mm} = 20 + 35.3 + 41.1 + 32.3 (X + A + B + A)$

$55.3 \text{ mm} = 20 + 35.3 (X + A)$

4.3 Tandem pumps dimensions (special version with shaft seal between the pumps)

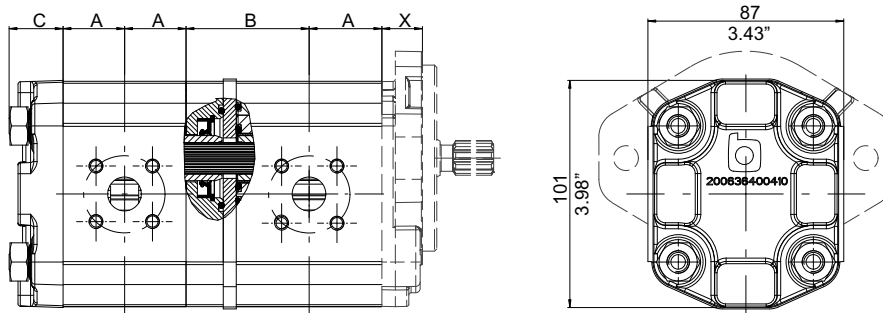

Pump size	A		B		C*	
	mm	inches	mm	inches	mm	inches
AP212/4.5	24.3	0.96	46.6	1.83	28	1.10
AP212/6.5	25.8	1.02	48.1	1.89		
AP212/8.5	27.3	1.08	49.6	1.95		
AP212/11	29.3	1.54	51.6	2.03		
AP212/15	32.3	1.27	54.6	2.15		
AP212/19	35.3	1.39	57.6	2.27		
AP212/22	37.6	1.48	59.9	2.36		
AP212/26	40.6	1.60	62.9	2.48		

C*: dimensions with standard back cover in cast iron .
For other back covers dimension see section 3.6

4.3.1 Special version, dimensions example

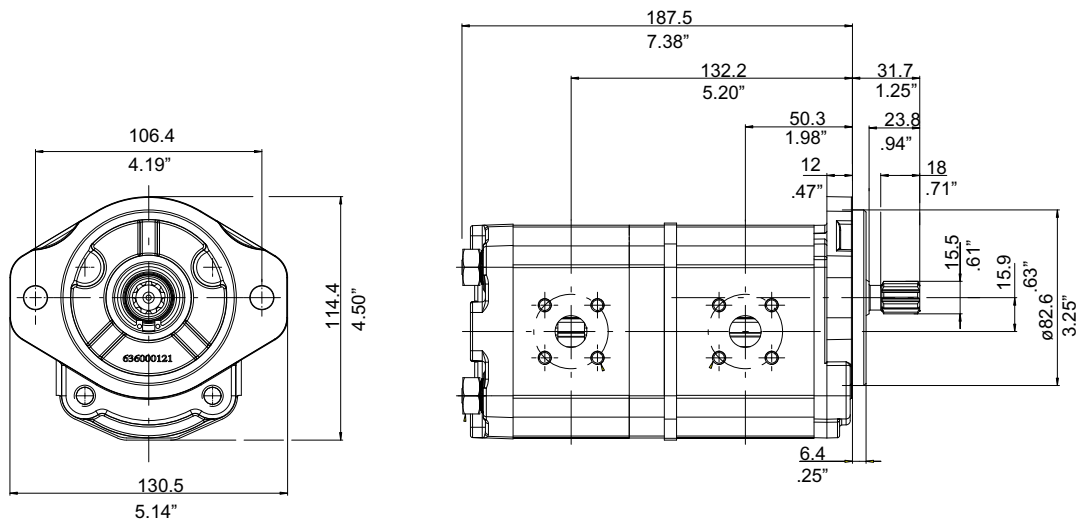

Example

Total length: 183.5 mm = 18 + 32.3 + 54.6 + 27.3 + 27.3 + 28 (X + A + B + A + A + C)

Port position: 132.2 mm = 18 + 32.3 + 54.6 + 27.3 (X + A + B + A)

50.3 mm = 18 + 32.3 (X + A)

4.4 Triple pumps dimensions (standard version without shaft seal between the pumps)

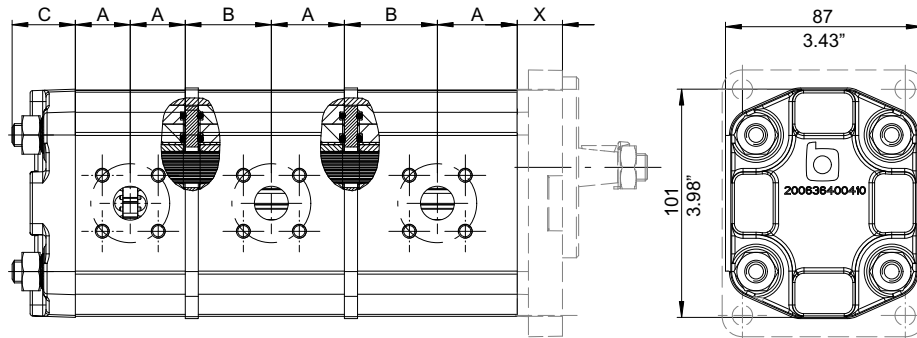

Pump size	A		B		C*	
	mm	inches	mm	inches	mm	inches
AP212/4.5	24.3	0.96	30.1	1.19	28	1.10
AP212/6.5	25.8	1.02	31.6	1.24		
AP212/8.5	27.3	1.08	33.1	1.30		
AP212/11	29.3	1.54	35.1	1.38		
AP212/15	32.3	1.27	38.1	1.50		
AP212/19	35.3	1.39	41.1	1.62		
AP212/22	37.6	1.48	43.4	1.71		
AP212/26	40.6	1.60	46.4	1.83		

C*: dimensions with standard back cover in cast iron .
For other back covers dimension see section 3.6

4.4.1 Standard versions, dimensions example

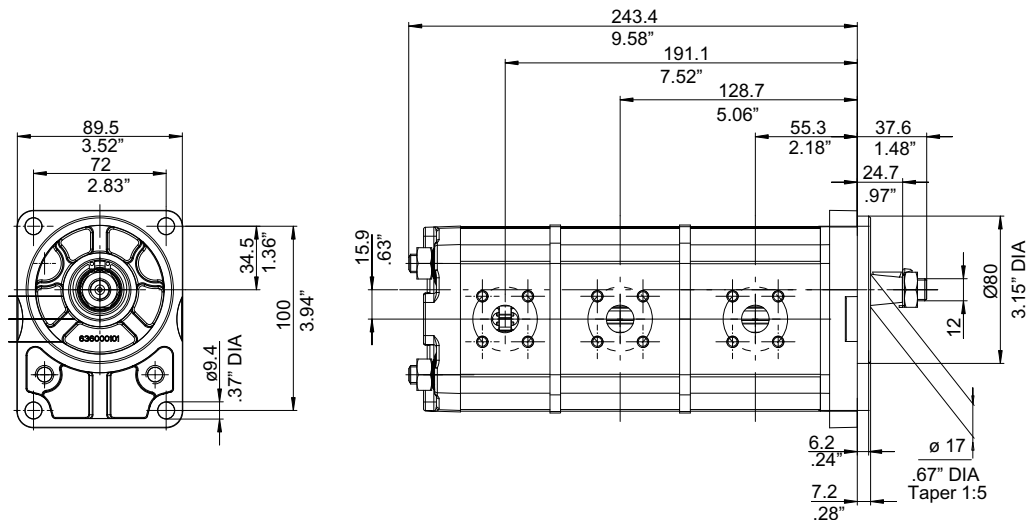

Example

Total length: $243.4 \text{ mm} = 20 + 35.3 + 41.1 + 32.3 + 38.1 + 24.3 + 24.3 + 28 \text{ (X + A + B + A + B + A + A + C)}$

Port position: $191.1 \text{ mm} = 20 + 35.3 + 41.1 + 32.3 + 38.1 + 24.3 \text{ (X + A + B + A + B + A)}$

$128.7 \text{ mm} = 20 + 35.3 + 41.1 + 32.3 \text{ (X + A + B + A)}$

$55.3 \text{ mm} = 20 + 35.3 \text{ (X + A)}$

4.5 Triple pumps dimensions (special version with shaft seal between the pumps)

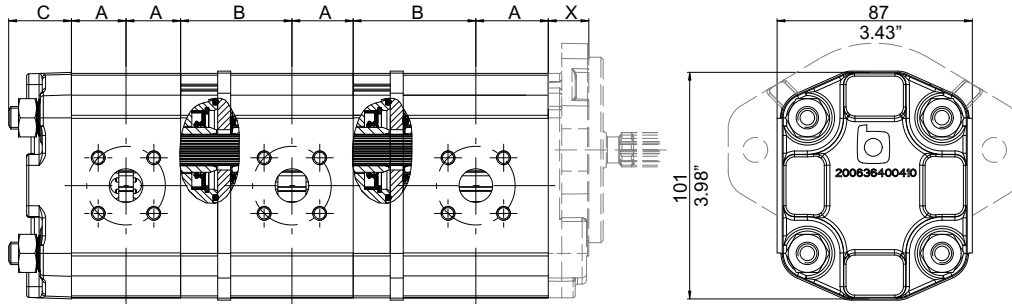

Pump size	A		B		C*	
	mm	inches	mm	inches	mm	inches
AP212/4.5	24.3	0.96	46.6	1.83	28	1.10
AP212/6.5	25.8	1.02	48.1	1.89		
AP212/8.5	27.3	1.08	49.6	1.95		
AP212/11	29.3	1.54	51.6	2.03		
AP212/15	32.3	1.27	54.6	2.15		
AP212/19	35.3	1.39	57.6	2.27		
AP212/22	37.6	1.48	59.9	2.36		
AP212/26	40.6	1.60	62.9	2.48		

C*: dimensions with standard back cover in cast iron .
For other back covers dimension see section 3.6

4.5.1 Special version, dimensions example

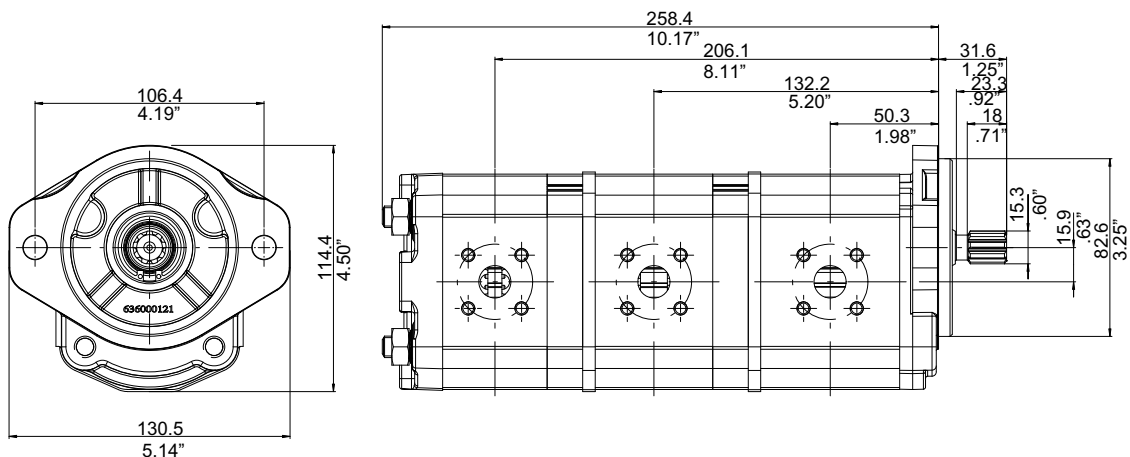

Example

Total length: $258.4 \text{ mm} = 18 + 32.3 + 54.6 + 27.3 + 49.6 + 24.3 + 24.3 + 28 (X + A + B + A + B + A + A + C)$

Port position: $206.1 \text{ mm} = 18 + 32.3 + 54.6 + 27.3 + 49.6 + 24.3 (X + A + B + A + B + A)$

$132.2 \text{ mm} = 18 + 32.3 + 54.6 + 27.3 (X + A + B + A)$

$50.3 \text{ mm} = 18 + 32.3 (X + A)$

4.6 How to order tandem pumps (with or without shaft seal between the pumps)

1st PUMP				2nd PUMP				1st BODY				2nd BODY																											
1	2	3	4	2	3	4	5	6	7	8	9	10	11	9	10	11	12	13																					
A	P	2	1	2	/	1	1	L	N	-	2	1	2	/	8	.	5	L	N	-	S	-	A	0	S	-	1	C	N	-	1	C	N	-	V	E	1	6	P

4.7 How to order triple pumps (with or without shaft seal between the pumps)

1st PUMP				2nd PUMP				3rd PUMP				1st BODY			2nd BODY			3rd BODY																																	
1	2	3	4	2	3	4	5	6	7	8	9	10	11	9	10	11	9	10	11	12	13																														
A	P	2	1	2	/	1	9	L	N	-	2	1	2	/	1	5	L	N	-	2	1	2	/	1	1	L	N	-	S	-	A	0	S	-	1	C	N	-	1	C	N	-	1	C	N	-	V	E	1	6	-

1 Function

AP= single gear pump - unidirectional
APR = single gear pump - reversible

2 Series

212

3 Displacement

4.5= 4.4 cm³/rev
6.5= 6.4 cm³/rev
8.5= 8.4 cm³/rev
11= 11.1 cm³/rev
15= 15.1 cm³/rev
19= 19.2 cm³/rev
22= 22.2 cm³/rev
26= 26.2 cm³/rev

4 Version

Omitted if 12 teeth standard
LN= 12 teeth Low Noise version

5 Rotation

S = left-hand rotation
D = Right-hand rotation
Omitted if reversible version

6 Shaft end code

see page section 3.3

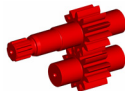

7 Shaft seal material type code

see page section 3.4.1



8 Front cover series/material with/without bearing code

see page section 3.4.2 and 3.4.3



9 Type of ports code

see page section 3.5



10 Inlet/outlet port size code combination

see page section 3.5

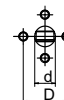

11 Body material + seal material code

see section 3.5.1

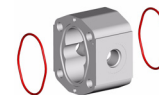

12 Back cover type / Valve setting value

see section 3.6



13 For Tandem or multiple pumps with or without shaft seal between the pumps

Omitted if without shaft seal between the pumps (standard versions)
P= with shaft seal between the pumps (special versions)

4.8 Tandem pumps dimensions AP212 + AP100 (with shaft seal between the pumps)

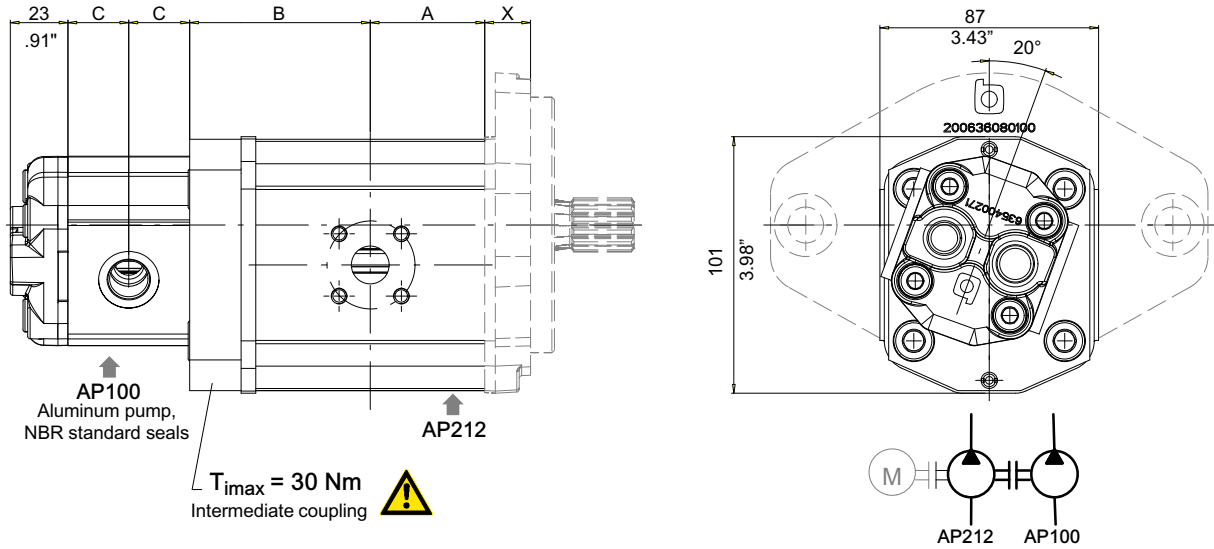

AP212 Pump size	A		B	
	mm	inches	mm	inches
AP212/4.5	24.3	0.96	50.6	1.99
AP212/6.5	25.8	1.02	52.1	2.05
AP212/8.5	27.3	1.08	53.6	2.11
AP212/11	29.3	1.54	55.6	2.19
AP212/15	32.3	1.27	58.6	2.31
AP212/19	35.3	1.39	61.6	2.43
AP212/22	37.6	1.48	63.9	2.52
AP212/26	40.6	1.60	66.9	2.63

AP100 Pump size	Displacement		C		Max. Pressure (*)					
	cm ³ /rev	Cu. In. P. R.	C		P1		P2		P3	
			mm	inches	bar	P.S.I.	bar	P.S.I.	bar	P.S.I.
AP100/1.2	1.2	.073	21.6	0.85	210	3000	250	3600	280	4000
AP100/1.7	1.7	.103	22.6	0.89	210	3000	250	3600	280	4000
AP100/2.5	2.5	.152	24.2	0.95	210	3000	250	3600	280	4000
AP100/3.5	3.5	.213	26.4	1.04	210	3000	230	3300	250	3600
AP100/4.3	4.3	.262	28.2	1.11	210	3000	230	3300	250	3600
AP100/5	5.0	.305	29.6	1.17	210	3000	230	3300	250	3600
AP100/6.5	6.5	.396	32.1	1.26	190	2700	220	3150	240	3400
AP100/8	7.8	.476	34.9	1.37	180	2600	210	3000	230	3300
AP100/10	10.0	.610	39.4	1.55	150	2150	180	2600	200	2900

IMPORTANT!: Common suction not available



Attention: (*) The max pressure is function of max admitted intermediate torque

4.8.1 AP100 port types available

Port type	Ordering code	Ø Diameter	Dimension (mm - inch)	
			Suction	Pressure
	2	d	12- .47"	12 - .47"
		D	30 - 1.18"	30 - 1.18"
	4		3/8" (Depth 13-.50")	3/8" (Depth 13-.50")
			50+5 Nm	50+5 Nm
	8		3/4" - 16 UNF-2B (SAE8)	9/16" - 18 UNF-2B (SAE6)
			55+10 Nm	30+10 Nm

4.9 How to order tandem pumps AP212 + AP100 (with shaft seal between the pumps)

1st PUMP				2nd PUMP				1st BODY			2nd BODY					
1	2	3	4	2	3	5	6	7	8	9	10	11	9			
A	P	2	1 2 / 1 1 L N -	1	0 0 / 6 . 5 -	S	-	A	0	S	-	4	B	N	-	4

- 1 Function**
AP= single gear pump - unidirectional
APR = single gear pump - reversible
- 2 Series**
212 and 100
- 3 Displacement**

AP212	AP100
4.5= 4.4 cm ³ /rev	1.2= 1.2 cm ³ /rev
6.5= 6.4 cm ³ /rev	1.7= 1.7 cm ³ /rev
8.5= 8.4 cm ³ /rev	2.5= 2.5 cm ³ /rev
11= 11.1 cm ³ /rev	3.5= 3.5 cm ³ /rev
15= 15.1 cm ³ /rev	4.3= 4.3 cm ³ /rev
19= 19.2 cm ³ /rev	5 = 5.0 cm ³ /rev
22= 22.2 cm ³ /rev	6.5= 6.5 cm ³ /rev
26= 26.2 cm ³ /rev	8 = 7.8 cm ³ /rev
	10= 10.0 cm ³ /rev

- 7 AP212 shaft seal material type code**
see page section 3.4.1
- 8 AP212 front cover series/material with/without bearing code**
see page section 3.4.2 and 3.4.3

- 4 AP212 version**
Omitted if 12 teeth standard
LN= 12 teeth Low Noise version
- 5 Rotation**
S = left-hand rotation
D = Right-hand rotation
Omitted if reversible version

- 9 AP212 type of ports code**
see page section 3.5
- 10 AP212 inlet/outlet port size code combination**
see page section 3.5

- 6 AP212 shaft end code**
see page section 3.3

- 11 AP212 body material + seal material code**
see section 3.5.1
- 12 AP100 type of ports code**
see section 4.8.1

5 Rotation changing instructions

For the AP212 pumps with unidirectional left (S) or right (D) rotation (not for 287S-SAEB pump) it is possible to change the rotation direction of the entire range without having to replace any component. To ensure a good technical result, we recommended in any case that such inversion should be carried out at our factory.

Following we represented a procedure for the pump rotation inversion, here in example a counter-clockwise rotation pump (S). To obtain an clockwise-rotation (D) see the following pictures/instructions.

Picture -1-

Initial configuration "Left" (S)

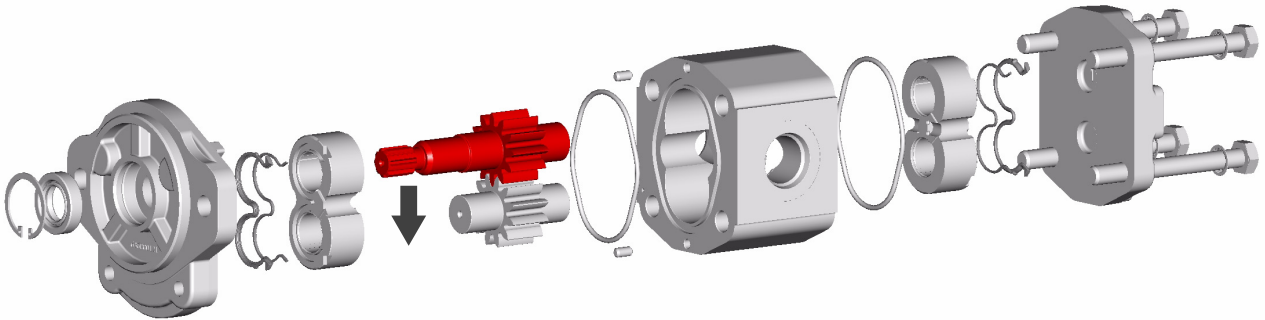
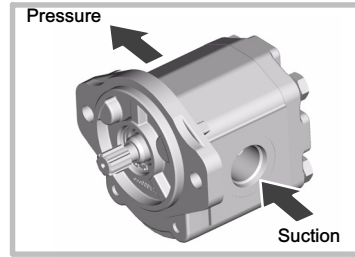

Picture -2-

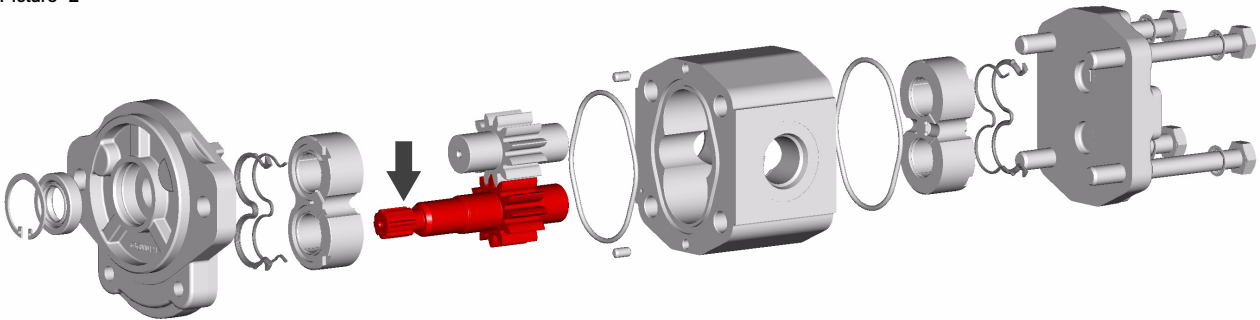

Picture -3-

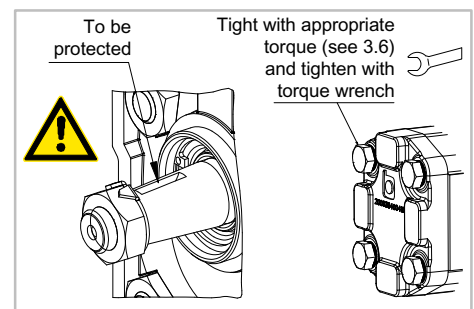
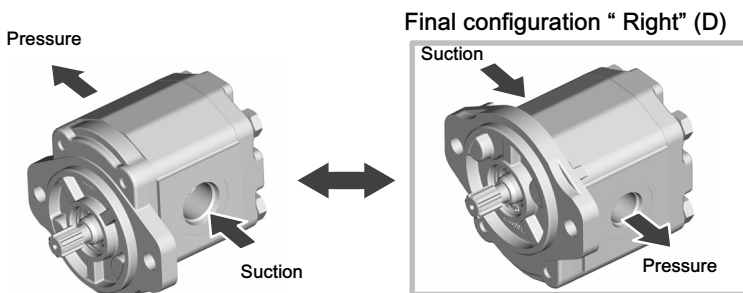
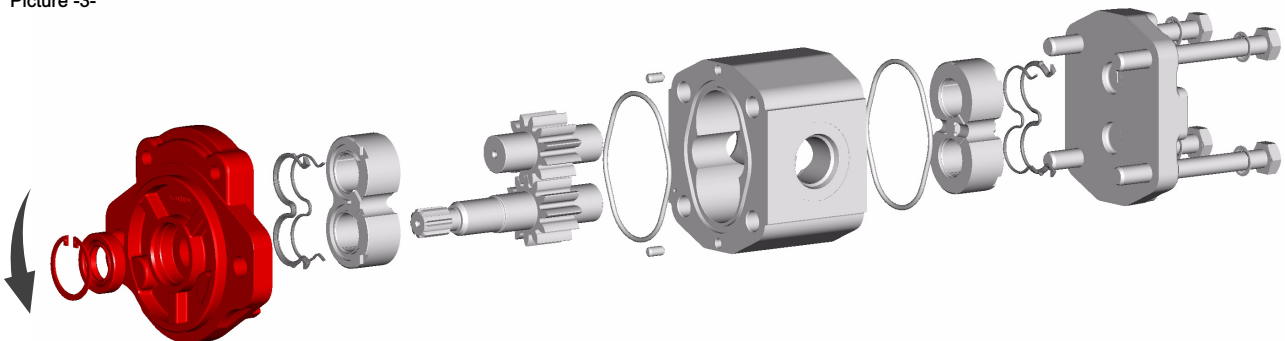

6 Pumps seal kit NBR standard type

The seal Kit code includes:
OR and shaft seal

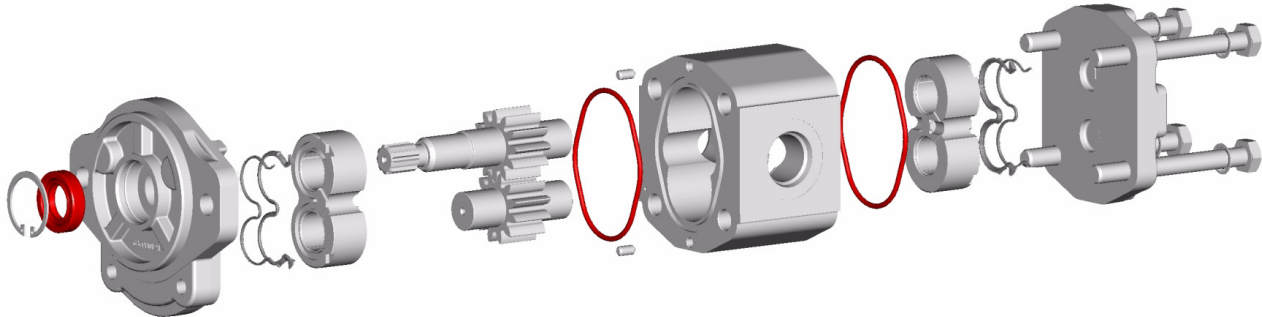

Type	Code
AP/APR212	200974001570
Tandem AP212 + AP212 NBR (without shaft seal between the pumps)	200974001580
Tandem AP212 + AP212 + PAR NBR (with shaft seal between the pumps)	200974001590

Minimum kit order quantity is requested: please contact our Sales Center

7 Product identification plate

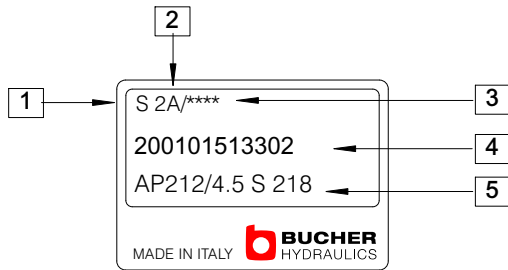

- 1 : Rotation (D= Clockwise rotation - S= Counterclockwise rotation)
- 2 : Manufacturing year and month
- 3 : Progressive identification no. (optional)
- 4 : Bucher Hydraulics S.p.A. product code
- 5 : Description

Single pumps approximate weights

Pump	Weight Kg
AP-APR212/4.5	2.5
AP-APR212/6.5	2.6
AP-APR212/8.5	2.7
AP-APR212/11	2.8
AP-APR212/15	3.0
AP-APR212/19	3.2
AP-APR212/22	3.3
AP-APR212/26	3.4

N.B.: The weight refers to pumps with aluminium front cover and standard cast iron back cover.

Manufacturing month	Manufacturing year							
	2010	2011	2012	2013	2014	2015	2016	2017
January	0A	1A	2A	3A	4A	5A	6A	7A
February	0B	1B	2B	3B	4B	5B	6B	7B
March	0C	1C	2C	3C	4C	5C	6C	7C
April	0D	1D	2D	3D	4D	5D	6D	7D
May	0E	1E	2E	3E	4E	5E	6E	7E
June	0F	1F	2F	3F	4F	5F	6F	7F
July	0G	1G	2G	3G	4G	5G	6G	7G
August	0H	1H	2H	3H	4H	5H	6H	7H
September	0I	1I	2I	3I	4I	5I	6I	7I
October	0J	1J	2J	3J	4J	5J	6J	7J
November	0K	1K	2K	3K	4K	5K	6K	7K
December	0L	1L	2L	3L	4L	5L	6L	7L

8 Application form

Date:			
Contact:			
Customer:			
Location:			
Overall quantity per year:			
Minimum batch size:			
Delivery time requested:	Feasibility:	Prototypes:	Series:
Target price:			
Type of application:			

External gear pump general data					
Rotation	S	D	R	Speed range	
Displacement: Single pump (cm ³ /rev)				Continuous work pressure (bar)	1st 2nd 3rd
Double pump (cm ³ /rev)	1st	2nd		Peak work pressure (bar)	1st 2nd 3rd
Multiple pump (cm ³ /rev)	1st	2nd	3rd	Oil type	
Drive shaft				Oil temperature (°C)	min max
Port type				Oil viscosity (cSt)	min max
Front cover type				Suction line pressure	
Bearing support				Voltage	
Front cover material				Drain case pressure	
Intermediate cover (with or without shaft seal)	with	without		Radial load (N)	
Back cover type/circuit				Axial load (N)	
Back cover material	aluminium	cast iron		Working hours per year	
Valves				Cycles per year	

Additional notes:

info.it@bucherhydraulics.com

www.bucherhydraulics.com

© 2012 by Bucher Hydraulics S.p.A, I-42124 Reggio Emilia

All rights reserved.

Data is provided for the purpose of product description only, and must not be construed as warranted characteristics in the legal sense. The information does not relieve users from the duty of conducting their own evaluations and tests. Because the products are subject to continual improvement, we reserve the right to amend the product specifications contained in this catalogue.

Classification: 410.110.000